



DCN No.
LAT-XR-06135-01

LAT PROJECT DOCUMENT CHANGE NOTICE (DCN)

SHEET 1 OF 1

ORIGINATOR: Dave Nelson		PHONE: 650-926-4652	DATE: 3/25/05
CHANGE TITLE: DCN for TEM/TPS Thermal Vacuum Test Procedure		ORG.:	
DOCUMENT NUMBER	TITLE	NEW REV.	
LAT-TD-03631	TEM/TPS Thermal Vacuum Test Procedure	07	

CHANGE DESCRIPTION (FROM/TO):
Please see LAT-XR-06136-01 for changes to this document

REASON FOR CHANGE:

ACTION TAKEN: Change(s) included in new release DCN attached to document(s), changes to be included in next revision
 Other (specify):

DISPOSITION OF HARDWARE (IDENTIFY SERIAL NUMBERS):	DCN DISTRIBUTION:
<input checked="" type="checkbox"/> No hardware affected (record change only)	
<input type="checkbox"/> List S/Ns which comply already:	
<input type="checkbox"/> List S/Ns to be reworked or scrapped:	
<input type="checkbox"/> List S/Ns to be built with this change:	
<input type="checkbox"/> List S/Ns to be retested per this change:	

SAFETY, COST, SCHEDULE, REQUIREMENTS IMPACT? YES NO
If yes, CCB approval is required. Enter change request number:

APPROVALS	DATE	OTHER APPROVALS (specify):	DATE
ORIGINATOR: D. Nelson (signature on file)	3/29/05	Thermal- J. Goodman (signature on file)	3/29/05
ORG. MANAGER: G. Haller (signature on file)	3/25/05		
PSA- Darren Marsh (signature on file)	3/26/05		
Manufacturing- R. Patterson (signature on file)	3/25/05		
Co-Author- L. Sapozhnikov (signature on file)	3/25/05		
DCC RELEASE: Natalie Cramar (signature on file)	3/29/05	Doc. Control Level: <input checked="" type="checkbox"/> Subsystem <input type="checkbox"/> LAT IPO <input type="checkbox"/> GLAST Project	

DCN No: LAT-XR-06135-01

	Document # LAT-TD-03631-07	Date effective March 22, 2005
	Author(s) Dave Nelson Roger Williams Leonid Sapozhnikov	Supersedes Rev 6
	Subsystem/Office	
Document Title Tower Electronics Module (TEM)/Tower Electronics Module Power Supply (TPS) Thermal Vacuum Test Procedure		

Hard copies of this document are for REFERENCE ONLY and should not be considered the latest revision.

TEM/TPS Thermal Vacuum Test Procedures

CHANGE HISTORY LOG

Revision	Effective Date	Description of Changes
01	20 July 2004	Initial version
02	31 Jan 2005	(unreleased) Chamber DAQ software changes and test profile changes
03	4 Feb 2005	Modified coordination between chamber operations and TEM/TPS test operations Changed vacuum level from 1.0e-5 to 5.0e-5. Moved turn-on tests to the end of the dwell for acceptance test temperatures
04	15 Feb 2005	Changed Acceptance Test procedure to agree with revised DAQ software
05	16 Feb 2005	Changed Qualification Test procedure to agree with revised DAQ software
06	10 Mar. 2005	Changed Para 5.1.3.1, 5.2.7, 5.3.3.1, 5.3.4.1 and 5.3.8.9, corrected data sheets that were out of printer margin, corrected auto numbering errors, changed a few tolerances in the data sheets per the TEM RE, Adding an Emergency Shut-Down Procedure in appendix D and 5.1.4.
07	22 Mar. 2005	Added text and notes for second test setup, changes are throughout the document.

Hard copies of this document are for REFERENCE ONLY and should not be considered the latest revision.

Table of Contents -TOC

1. SCOPE	6
2. DEFINITIONS AND ACRONYMS	6
2.1 Definitions.....	6
2.2 Acronyms.....	7
3. REFERENCES	8
3.1 Applicable Documents.....	8
4. REQUIREMENTS.....	9
4.1 General.....	9
4.2 Test Personnel and Descriptions.....	10
4.3 Test Readiness Review (TRR) and Post Test Review (PTR).....	11
4.4 Contamination Control.....	11
4.5 Handling and Transportation	12
4.6 ESD.....	12
4.7 Mate/Demate Connectors.....	12
4.8 Test Equipment	12
4.9 Test Data and Review	13
4.10 Flight Hardware Log Book	13
4.11 Nonconforming Test Data, Equipment and Software.....	13
4.12 Redlining and Blacklining Documents	13
4.13 Quality Assurance.....	14
4.13.1 Product Assurance Requirements	14
4.14 Warnings, Cautions, and Notes.....	15

Hard copies of this document are for REFERENCE ONLY and should not be considered the latest revision.

TEM/TPS Thermal Vacuum Test Procedure

4.15	Testing Safety	16
4.16	SLAC Safety, ES & H Manual	16
5.	PROCEDURE.....	17
5.1	Test Procedure Instructions/Information	18
5.1.1	Test Prerequisites	18
5.1.2	Test Sequence	18
5.1.3	Test Equipment	19
5.1.4	Emergency Shut-Down Procedure.....	19
5.1.5	Test Fixtures.....	21
5.1.6	User Interface.....	21
5.1.7	Participant List.....	21
5.2	Test Setup and Validation.....	22
5.2.1	Open Chamber	22
5.2.2	Inspection of Chamber	22
5.2.3	Installation of the TEM Test Board and TEM Load Board	23
5.2.4	Setup of the Test Equipment and Test Cable.....	25
5.2.5	Test Setup of the Golden TEM/TPS Assembly	25
5.2.6	Validation of the Golden TEM/TPS Assembly	25
5.2.7	Test setup of the Flight TEM/TPS Assembly.....	26
5.2.8	Validation of the Flight TEM/TPS Assembly	28
5.2.9	Close Chamber	28
5.2.10	Boot Up DAS Software	28
5.2.11	Depressurization (Pump Down).....	28

Hard copies of this document are for REFERENCE ONLY and should not be considered the latest revision.

TEM/TPS Thermal Vacuum Test Procedure

5.3	Thermal Vacuum Test.....	29
5.3.1	Test Definitions.....	30
5.3.2	Qualification Start Test.....	32
5.3.3	Qualification Test for Cycle 1.....	37
5.3.4	Qualification Test for Cycle 2 through 11	43
5.3.5	Qualification Test for Cycle 12.....	47
5.3.6	Shutdown Cycle of the Qualification Test.....	51
5.3.7	Acceptance Start Test	53
5.3.8	Acceptance Test for Cycle 1	57
5.3.9	Acceptance Test for Cycle 2-3.....	63
5.3.10	Acceptance Test for Cycle 4.....	67
5.3.11	Shutdown Cycle of the Acceptance Test	71
5.4	Chamber Shutdown.....	73
5.4.1	Pressurization (Venting)	73
5.4.2	Opening Chamber	73
5.4.3	Collecting Test Data	74
	Appendix A (Data Sheets and Covers).....	75
	Appendix B (Connector Mate/Demate Log).....	92
	Appendix C (CPT and LPT definition).....	94
	Appendix D (Emergency Shut-Down Procedure)	96

1. SCOPE

The purpose of this test is to verify workmanship, functionality and thermal design of the Tower Electronics Module (TEM)/ Tower Electronics and Module Power Supply (TPS) in a thermal-vacuum (TV) environment. System performance testing will be characterized at thermal extremes. This test procedure details the sequence and the methods to be followed in performing the TV testing of the TEM/TPS in accordance with the LAT T & DF Test Plan, LAT-TD-00296. The TV test results will be recorded within this document.

2. DEFINITIONS AND ACRONYMS

The following terms, abbreviations, and acronyms are used in this document:

2.1 Definitions

A, An	Analog
D, Dg	Digital
F	Functional
Hz	Hertz, unit of frequency
MHz	Megahertz
Ω	Ohm, unit of electrical resistance
s, sec	Seconds
V	Volt
W	Watt

2.2 Acronyms

AIDS	Assembly and Inspection Data Sheet
BOB	Break-Out-Box
CAL	Calorimeter
CPT	Comprehensive Performance Test
EGSE	Electrical Ground Support Equipment
ETech	Electrical Technician Electrical Ground Support Equipment
GASU	Global trigger Anti-collision Spacecraft Unit
LPT	Limited Performance Test
MTech	Mechanical Technician
PTR	Post Test Review
QAE	Quality Assurance Engineer
TC	Test Conductor
TD	Test Director
TEM	Tower Electronics Module
TKR	Tracker
TPS	Tower Power Supply
TRR	Test Readiness Review
UUT	Unit Under Test

3. REFERENCES

The following documents are referenced within this document:

3.1 Applicable Documents

Document Number	Description
SPECIFICATIONS	
LAT-TD-00778	LAT Environmental Specification
PLANS	
LAT-MD-00039	Performance Assurance Implementation Plan
LAT-MD-00078	GLAST LAT System Safety Program Plan
LAT-MD-00228	LAT CAL, TKR, and T&DF Contamination Control Plan
LAT-TD-00296	T & DF Test Plan
LAT-MD-00404	LAT Contamination Control Plan
LAT-MD-00408	LAT Program Instrument Performance Verification Plan
LAT-MD-01376	LAT Integration and Test Subsystem Test Plan
LAT-MD-01386	LAT Integration and Test Subsystem Facility Plan
OTHER	
LAT-MD-00091	GLAST Quality Manual
LAT-MD-00471	Control of Nonconforming Product
LAT-MD-00472	Corrective and Preventative Action
LAT-MD-00473	Handling, Storage, Packing, Preservation and Delivery
LAT-MD-02541	Thermal Vacuum Chamber Operation Procedure
LAT-MD-03474	Redline/Blackline Engineering Documents Procedure
LAT-TD-04085	TEM/TPS Performance Test
LAT-PS-04459	LAT I&T Mate and Demate Workmanship Standard

4. REQUIREMENTS

This section lists the requirements that shall be utilized during design, development, manufacture, assembly, testing and storage.

4.1 General

The Performance Assurance Implementation Plan, LAT-MD-00039 shall be utilized to verify that the products produced by the GLAST LAT project intended for design qualification, flight and critical ground support equipment usage meet the required levels of quality and functionality for their intended purposes.

This document shall follow the LAT Program Instrument Performance Verification Plan LAT-MD-00408 which details the LAT and its subsystem verification test flow.

The LAT T & DF Test Plan, LAT-TD-00296 shall be utilized to address the overall requirements at engineering model, qualification and production level phases. This document defines the time period from post circuit board fabrication until electronic box delivery to LAT Integration and Test.

Testing within this document shall conform to the requirements stated in LAT Performance and Operations Test Plan LAT-MD-02730 for all testing that relates to LAT I & T.

4.2 Test Personnel and Descriptions

Responsible Engineer (RE): Responsible for planning, scheduling, and coordinating all resources and organizations to accomplish the test. He shall verify test set-up and execution conforms to all the applicable test plans and procedures. The RE is responsible for test procedure changes or revisions as a result of errors and omissions discovered during testing. The RE may run tests. The RE shall oversee completion of a final test report.

- Test Engineer (TE): shall operate the chamber per procedure, and execute tests under the direction of the RE
- Quality Assurance (QA): is responsible for reviewing and approving test procedures, approving red line and black line changes to the procedures, verifying the test is being run according to approved procedures, and signing the data packages. QA shall witness TV testing of each TTM/TPS and review/approve EIDP for each test. QA shall witness setup of the TEM/TPS in the TV chamber and shall verify thermistor locations on TEM/TPS and fixture per test procedure.

4.3 Test Readiness Review (TRR) and Post Test Review (PTR)

The TRR and PTR are organizational meetings that shall be held at the appropriate times to inform all parties about the testing that is to be accomplished and has been completed. The TRR and PTR meetings are defined in the GLAST LAT Integration and Test Subsystem Test Plan, LAT-MD-01376 Environmental Conditions

Testing performed in accordance with this document shall conform to standard environmental test conditions unless specific test requirements within this document exist. Standard Environmental test conditions are as follows:

- Dynamic Mechanical Conditions: No load, at rest
- Temperature: 18.3 to 25.7.°C
- Atmospheric Pressure: Uncontrolled local conditions
- Humidity: 30% to 50% RH for testing when the Calorimeter or Engineering Model (EM) Calorimeters are present. For all other testing 30% to 60% RH is required.

This document shall follow the LAT Environmental Specification, LAT-SS-00778 for all testing where non standard environments are required. The Environmental Specification defines the thermal, vibration and on-orbit exposure design and test environments for the LAT instrument and its subsystems.

4.4 Contamination Control

The Contamination Control Plan defines the overall contamination control requirements necessary to establish hardware cleanliness for the GLAST LAT program. When work is performed at SLAC follow LAT Integration and Test Subsystem Facility Plan, LAT-MD-01386. When work is performed elsewhere follow LAT Contamination Control Plan, LAT-MD-00404

4.5 Handling and Transportation

This document shall follow the requirements found in the Handling, Storage, Package, Preservation and Delivery document, LAT-MD-00473. This document establishes handling, storage, packaging and transportation practices adequate to maintain the safety, reliability and quality of SLAC LAT flight hardware items and achieve their damage free delivery to the place and time of ultimate use.

4.6 ESD

The CAL, TKR, T & DF Contamination Control Plan, LAT-MD-01386, and the LAT Contamination Control Plan, LAT-MD-00404, define the ESD requirements for the GLAST LAT program. When work is performed at SLAC follow LAT-MD-01386. When work is performed elsewhere follow LAT-MD-00404.

4.7 Mate/Demate Connectors

This document shall follow the requirements found in the Mate and Demate Workmanship Standard LAT-PS-04459 The mate/demate process shall be followed for each and every connector mate. This consists of a visual inspection of the interface, cleaning if required, and proper mating techniques.

4.8 Test Equipment

This document shall follow the requirements found in the LAT Program Instrument Performance Verification Plan, LAT-MD-00408, which defines calibration, accuracy, substitutions, etc. for the test equipment .

4.9 Test Data and Review

This document shall follow the requirements found in the LAT Program Instrument Performance Verification Plan, LAT-MD-00408, which defines the test data sheets and details the personnel that reviews test data. Test data shall be recorded on the data sheets that are found in Appendix A of this document. The data sheets and any supporting data shall use a cover sheet that is found in Appendix A of this document.

4.10 Flight Hardware Log Book

The LAT Program Instrument Performance Verification Plan, LAT-MD-00408 requires that a log of hardware installation, software installation, power ON and mates/demates to flight connectors shall be kept for each flight unit. The log book is part of the package that is deliverable to the customer.

4.11 Nonconforming Test Data, Equipment and Software

This document shall follow the requirements found in the Control of Nonconforming Product, LAT-MD-00471. This document establishes methods to identify and control nonconforming product developed by the LAT project team.

4.12 Redlining and Blacklining Documents

The users of this document shall follow the requirements found in the Redline/Blackline Engineering Documents Procedure, LAT-MD-03474.

4.13 Quality Assurance

This document shall follow the requirements found in the Corrective and Preventative Action document, LAT-MD-00472 and the GLAST Quality Manual, LAT-MD-00091 and LAT Program Instrument Performance Verification Plan, LAT-MD-00408.

The Corrective and Preventative Action document establishes the method to be used to initiate, implement, evaluate and record corrective and preventive actions. The GLAST Quality Manual defines the methods implemented by the GLAST LAT project to ensure consistent quality of all processes for procurement, design, development and production of flight hardware, flight software, calibration and all associated ground support equipment interfacing with flight hardware and software. The LAT Program Instrument Performance Verification Plan defines test configuration, data sheets and review of test results.

4.13.1 Product Assurance Requirements

The QAE shall witness the initial test setup and validation operations. In the event of a failure a Non Conformance Report (NCR) shall be written. The root cause and corrective action shall be identified and there shall be QAE approval before the operation is continued. Any deviation from this document requires approval from the QAE as well as the TC.

4.14 Warnings, Cautions, and Notes

The following SAFETY ALERTS are intended to create awareness of the potential safety hazards and the steps that must be taken to avoid accidents. These same alerts are used throughout this document to identify specific hazards that may endanger personnel and/or equipment.

Identification of every conceivable hazardous situation is impossible. Therefore, all personnel have the responsibility to diligently exercise safe practices whenever exposed to this equipment.

WARNING: Indicates a potential hazardous situation which, if not avoided, could result in death or injury.

CAUTION: Indicates a potential hazardous situation which, if not avoided, could result in damage to equipment.

Note: Indicates a notification of information that is important, but not hazard related.

4.15 Testing Safety

This document shall follow the requirements found in the GLAST LAT System Safety Program Plan, LAT-MD-00078 This document defines all phases of the LAT program including: design, development, fabrication, handling, transportation, storage, test, assembly and operation.

4.16 SLAC Safety, ES & H Manual

This document shall follow the requirements found in the SLAC Environment, Safety, and Health Manual, SLAC-I-720-0A29Z-001. This document defines the SLAC policy to support environmental protection, health, and safety in the workplace.

WARNING: A hot work permit is required for work on or around open connectors/circuits having:

- * **Voltage greater than 50V (AC or DC)**
- AND**
- * **Current supply capability greater than 5mA**
- OR any circuit having**
- * **Energy storage greater than 10 Joules ($E=1/2CV^2$)**

5. **PROCEDURE**

The Thermal Vacuum Chamber Operation Procedure LAT- TD-02541 and TEM/TPS Performance Procedure LAT-TD-04085 are used in conjunction this test procedure. Refer to and review the GLAST Thermal Vacuum Chamber Operation Procedure LAT-TD-02541 and TEM/TPS Performance Procedure LAT-TD-04085 before proceeding with the following procedure.

This procedure is used for Performance Testing of the circuits of the TEM/TPS. This document is written to include notes for testing two TEM/TPS assemblies.

Note: When two TEM/TPS assemblies are tested both test setups must meet the testing requirements before proceeding.

 If two TEM/TPS assemblies are tested a complete set of data sheets are to be filled out for each TEM test setup.

Unless otherwise noted use a DVM for all measurements.

Note: When performing measurements with a DMM connect the negative lead first.

5.1 Test Procedure Instructions/Information

This section provides the general instructions and information that are used and required to perform this procedure, including: test parameters, sequence, equipment and test participants.

5.1.1 Test Prerequisites

- This section describes processes and procedures that must be completed prior to performing the tests in this document.

5.1.2 Test Sequence

This section describes the requirements of the event sequence for performing this procedure. Tests are to be performed in the order listed in this document unless otherwise specified. It is permissible for Assembly Instruction Data Sheets (AIDS) to be used to change the order of tests or select a single test paragraph to be performed. In that case, the data sheet for the test performed will be included in the end item data package linked to the AIDS step that required it. Test sequencing can also be changed in a TRR and black lined into the test procedure.

5.1.3 Test Equipment

The test equipment listed below is necessary for the tests described in this procedure. If additional equipment is used, add it to the table below with the signature of the TC and QAE, proceed with the test.

5.1.3.1 EGSE

To record the test equipment, cables, connector savers and software:

Record the information for all equipment on the data sheet. See the list below for descriptions of the information to be recorded.

- Description and Manufacturer
- Model/LAT number
- Serial/Revision number
- Calibration due date (enter NA for non calibrated equipment)
- Validation completion date for all EGSE

5.1.4 Emergency Shut-Down Procedure

The shut-down process and who to contact is found in Appendix D of this document.

TEM/TPS Thermal Vacuum Test Procedure

The list below indicates the equipment that is used to perform this procedure:

Test Equipment Description, Manufacturer	Model/LAT Number
VME Crate, Dawn VME Products	11-1011777-2119
VME, TST-STP Trans card	LAT-DS-00999
VME SBC MVME2304 card, Motorola	PN MVME2304-0123
VME LCB Mezzanine card	LAT-TD-00860
Software for the local PC	Find at www-glast.slac.stanford.edu/IntegrationTest/ONLINE/updates/
Software for the local PC	
DC Power supply #1, BK Precision	BK 1697
DC Power supply #2, BK Precision	BK 1697
28 Volt supply cable	LAT-DS-03246
PS Control cable	LAT-DS-04831
TEM to GASU cable	LAT-DS-02106
LCB Transition board cable	LAT-DS-03247
TEM Test Board Assembly	LAT-DS-04465
CAT5 Ethernet cable	TRD855PL-50
RS-232 Cable	TDC003-7 (RECO98M connectors)
Digital Multimeter, Fluke/Meterman	87-III/38XR
Connector Savers (28 pin), L Com	DGBH28MF
Connector Savers (51 pin), Glenair	MWDM2L-51USP1
Connector Savers (69 pin), SLAC	LAT-DS-04724
Delay Line, Lemo To Bnc 4N, from SLAC Stores	STORES ID #078697
Thermal Vacuum Chamber, SLAC	LAT-DS-01043
Acrylic base adhesive tape, Saint Gobain	K102
Thermo coupler wire (8), Omega	T Type
DAQ Module, Omega	OMB-DAQ-55
DAQ Module, Omega	OMB-DAQ-56
Adaptor 28 Volt supply cable	LAT-DS-05663
Adaptor PS Control cable	LAT-DS-05661
Adaptor TEM to GASU cable	LAT-DS-05662
Torque Wrench	92407

Hard copies of this document are for REFERENCE ONLY and should not be considered the latest revision.

5.1.5 Test Fixtures

<u>Type</u>	<u>Description</u>
Plate Adaptor LAT-DS-05656	Secures the TEM/TPS unit to the hot/cold plate within the TV chamber

5.1.6 User Interface

<u>Type</u>	<u>Description</u>
DAS Software (SLAC)	Software- controls, monitors and records the environment conditions of the hardware and chamber.

5.1.7 Participant List

This section provides a data sheet to record test participants.

- 1) Record all test participants in the data sheet.

5.2 Test Setup and Validation

The Thermal Vacuum Chamber Operation Procedure LAT- TD-02541 and TEM/TPS Performance Procedure LAT-TD-04085 are used in conjunction this test setup procedure. Refer to GLAST Thermal Vacuum Chamber Operation Procedure LAT-TD-02541 and TEM/TPS Performance Procedure LAT-TD-04085 before proceeding with the following procedure.

- 1) Notify the QAE to witness test setup and validation. **Record** per the data sheet.

5.2.1 Open Chamber

- 1) Open the thermal vacuum chamber. Refer to GLAST Thermal Vacuum Chamber Operation Procedure LAT-TD-02541 to open the thermal vacuum chamber.

5.2.2 Inspection of Chamber

When inspecting the chamber refer to GLAST Thermal Vacuum Chamber Operation Procedure LAT-TD-02541.

- 1) Perform a visual inspection for of the chamber's hot/cold plate equipment.
- 2) At the hot/cold plate tubing connections check that there are no loose connections or indications of fluid leakage.
- 3) On the Thermo Haake controller, check that the Nitrogen supply is connected to the bath lid.
- 4) Check that the bath fluid levels are at the required level.
- 5) Wipe down the inside of the chamber and hot/cold plate with wiping pads and isopropyl alcohol, wearing gloves.

5.2.3 Installation of the TEM Test Board and TEM Load Board

CAUTION: When working with the electronic equipment wear ESD wrist bands at all times.

Note: When two TEM/TPS assemblies are tested both test setups must meet the testing requirements before proceeding.

If two TEM/TPS assemblies are tested a complete set of data sheets are to be filled out for each TEM test setup.

- 1) Install the TEM Test Board and TEM Load Board in the chamber. Refer to the TEM/TPS Performance Procedure LAT-TD-04085 and the Interconnect Diagram Figure.

TEM/TPS Thermal Vacuum Test Procedure

- 2) Install TPS plate adaptor to the hot/cold plate using 3/8" socket head cap screws (torque to 45 ft-lb) and 1/2" socket head cap screws (torque to 110 ft-lb). **Record** per the data sheet.

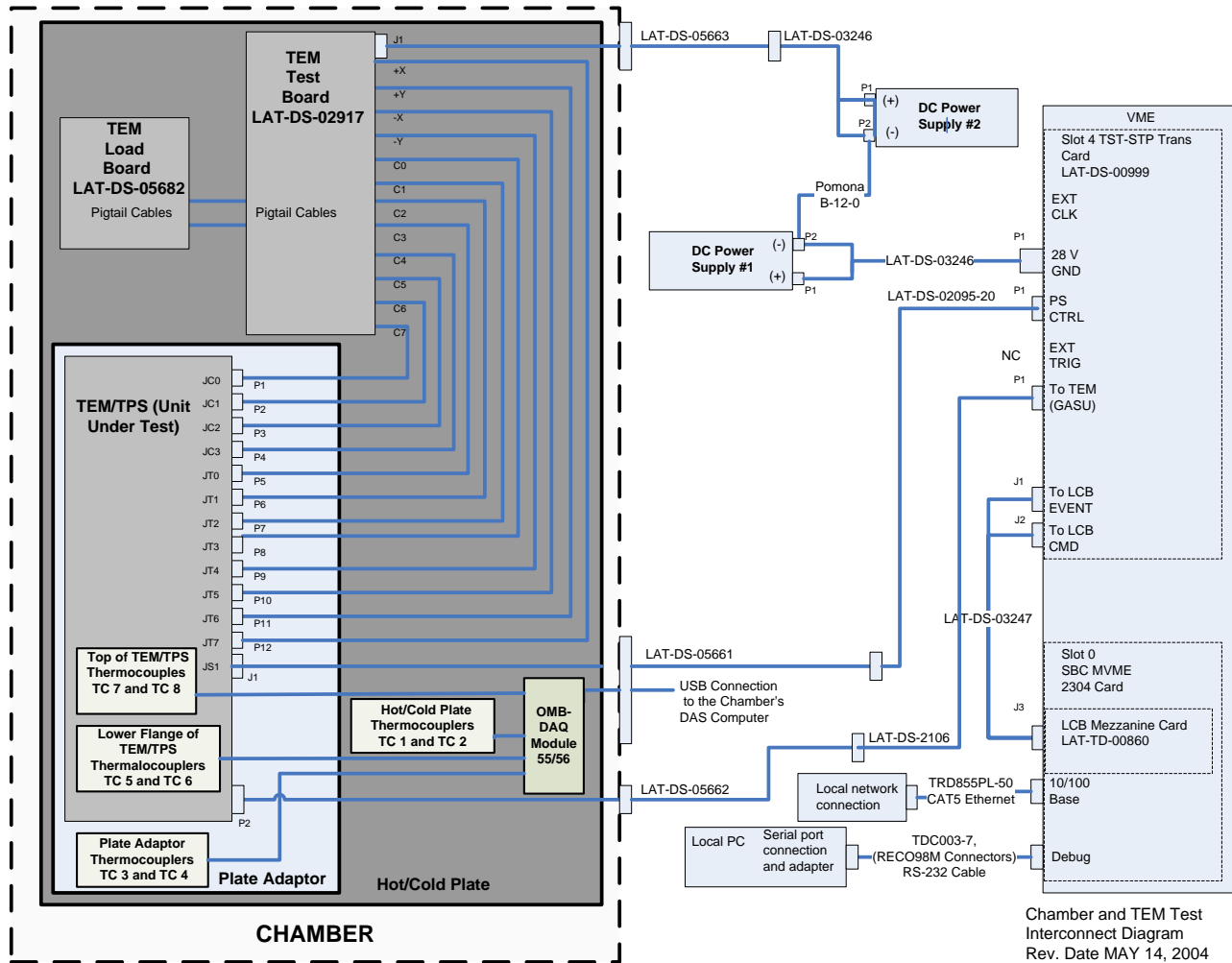

Figure 1. Interconnect Diagram

5.2.4 Setup of the Test Equipment and Test Cable

- 1) Setup the test cables, test cables adapter and power cables using the cable feed-through connectors of the TV chamber. Refer to the test setup within the TEM/TPS Performance Procedure LAT-TD-04085 and the Interconnect Diagram Figure.

5.2.5 Test Setup of the Golden TEM/TPS Assembly

- 1) Place a golden TEM/TPS assembly on the TPS plate adaptor. This TEM/TPS is used to validate the TEM/TPS test setup.
- 2) Connect test cables to the golden TEM/TPS. Refer to the test setup within the TEM/TPS Performance Procedure LAT-TD-04085 and the Interconnect Diagram Figure.

5.2.6 Validation of the Golden TEM/TPS Assembly

- 1) Validate the TEM/TPS test setup by performing the (COMPLETE) Comprehensive Performance Test at 20 MHz. Refer to the TEM/TPS Performance Procedure LAT-TD-04085 Attach to the Appendix A Cover. **Record** per the data sheet.
- 2) Disconnect test cables from the golden TEM/TPS assembly.
- 3) Remove the golden TEM/TPS assembly from the TPS plate adaptor.

5.2.7 Test setup of the Flight TEM/TPS Assembly

This procedure is used for Performance Testing of the circuits of the TEM/TPS. This document is written to include notes for testing two TEM/TPS assemblies.

Note: When two TEM/TPS assemblies are tested both test setups must meet the testing requirements before proceeding.

If two TEM/TPS assemblies are tested a complete set of data sheets are to be filled out for each TEM test setup.

This flight TEM/TPS assembly is the EUT to be used for qualification or acceptance testing.

- 1) Install a flight TEM/TPS assembly to the plate adaptor. Torque to 20 ft-lb. **Record** per the data sheet.
- 2) Connect the test cables to the flight TEM/TPS assembly. Refer to the test setup within the TEM/TPS Performance Procedure LAT-TD-04085 and the Interconnect Diagram Figure.

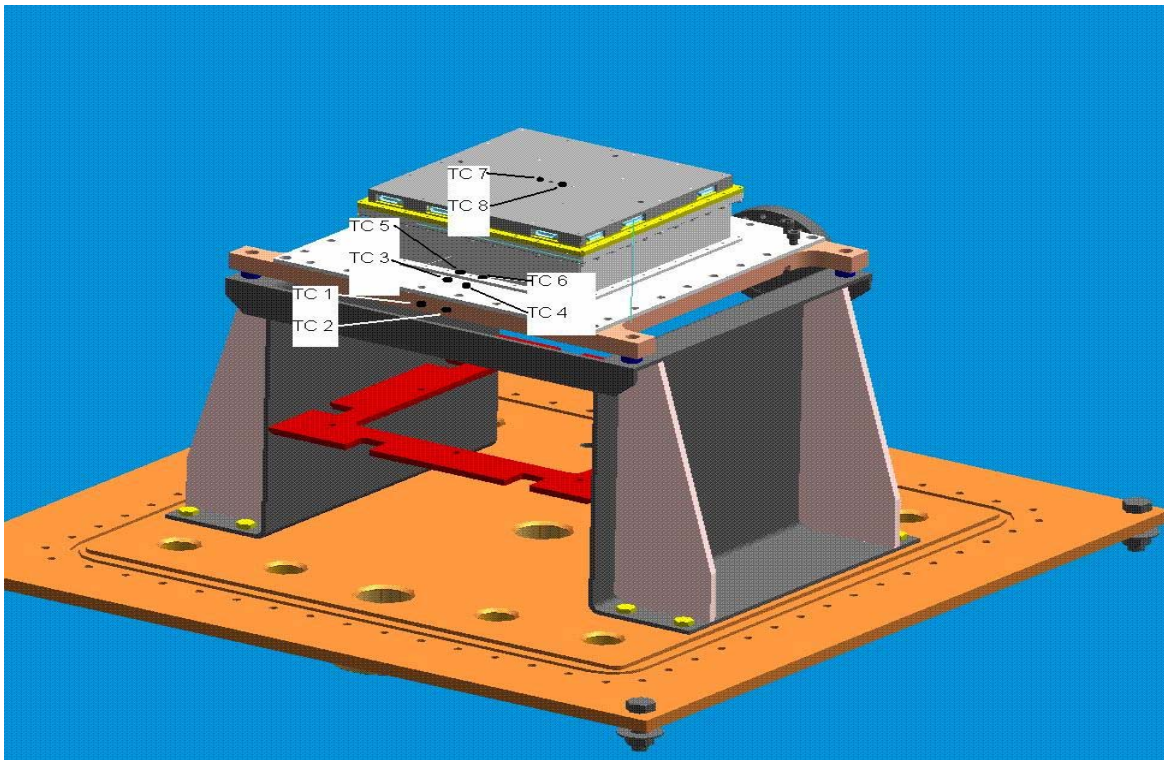

Figure 2. Thermo Couplers TC1-TC8 Placements

TEM/TPS Thermal Vacuum Test Procedure

- 3) Mechanically attach eight thermo couplers (TC 1-TC 8). Refer to the Thermo Couplers TC1-TC8 Placement Figure and Interconnect Diagram Figure.
 - a) (Two) TC 1 and TC2 on the hot/cold plate.
 - b) (Two) TC 3 and TC 4 on the plate adaptor.
 - c) (Two) TC 5 and TC 6 on the bottom flange of the TEM/TPS.
 - d) (Two) TC 7 and TC 8 on the top of the TEM/TPS Assembly.

- 4) Verify the operation of the TCs by setting the hot/cold plate temperature to 30°C. Allow the TCs to stabilize and verify all TCs are reading 30°C +/- 2°C. Record per the data sheet.

5.2.8 Validation of the Flight TEM/TPS Assembly

- 1) Validate the TEM/TPS test setup by performing the (COMPLETE) Comprehensive Performance Test at 20MHz. Refer to the TEM/TPS Performance Procedure LAT-TD-04085. Attach to the Appendix A Cover. **Record** per the data sheet.
- 2) Turn power OFF to the TEM/TPS as defined in Appendix C

5.2.9 Close Chamber

- 1) Close the thermal vacuum chamber. Refer to GLAST Thermal Vacuum Chamber Operation Procedure LAT-TD-02541 to close the thermal vacuum chamber.

5.2.10 Boot Up DAS Software

- 1) Using the DAS computer system, boot up of the DAS software. Refer to GLAST Thermal Vacuum Chamber Operation Procedure LAT-TD-02541.

5.2.11 Depressurization (Pump Down)

- 1) Pump down the thermal vacuum chamber. Refer to GLAST Thermal Vacuum Chamber Operation Procedure LAT-TD-02541 to pump down the thermal vacuum chamber.

5.3 Thermal Vacuum Test

The thermal vacuum test satisfies the requirements for qualification and acceptance testing as verification for the TEM/TPS as specified in the LAT Environmental Specification LAT-SS-00778 and LAT Instrument Performance Verification Plan LAT-MD-00408.

The Thermal Vacuum Chamber Operation Procedure LAT- TD-02541 and TEM/TPS Performance Procedure LAT-TD-04085 are used in conjunction with this test procedure. Refer to these documents before proceeding with the following procedure.

Note: When two TEM/TPS assemblies are tested both test setups must meet the testing requirements before proceeding.

 If two TEM/TPS assemblies are tested a complete set of data sheets are to be filled out for each TEM test setup.

5.3.1 Test Definitions

5.3.1.1 Timeline

The Test Timeline Figures below represent the qualification and acceptance test timelines. These timelines show when to open and close the chamber, test setup and shut down, test setup validation, and performance tests will take place. Deviations from these timelines shall be permitted at the discretion of the Test Director.

5.3.1.2 Cycles

Each thermal test shall be subject to a specified number of thermal cycles. Each cycle shall include a specified number of hour soaks at the specified high and low plateau temperature. A hot and cold survival soak shall be accomplished during the first cycle. On the first cycle an operational startup and turn off at the beginning of the transition to the hot and cold temperatures limit shall be accomplished. Also at the end of the each hot and cold soak beginning with the second cycle, an operational startup shall be accomplished.

The thermal test will be conducted at the specified qualification and acceptance temperature ranges. Throughout the test, the test temperatures shall not exceed the temperatures specified during hot soak and cold soak.

5.3.1.3 Vacuum

The thermal vacuum test of the TEM/TPS will be subject to the specified vacuum pressure (torr).

5.3.1.4 Performance

During this test, the TEM/TPS shall undergo both Comprehensive and Limited Performance Testing. These tests as shown in the Test Timeline Figures and are identified in the following sections.

Pump down the thermal vacuum chamber. Refer to GLAST Thermal Vacuum Chamber Operation Procedure LAT-TD-02541 to pump down the thermal vacuum chamber.

- 1) Comprehensive Performance Testing (CPT) shall provide verification of the full electrical function of the TEM/TPS electronics.
- 2) Limited Performance Testing (LPT) shall provide verification of selected elements of the electrical function of the TEM/TPS electronics.

5.3.1.5 Qualification and Acceptance Testing

During this test, the TEM/TPS shall be tested for the Qualification Test Limits or Acceptance Test Limits. These tests profiles are shown in the Test Timeline Figures and the test procedures that are specified in the following test sections.

5.3.2 Qualification Start Test

When perform the following test refer to the Qualification Thermal Vacuum Cycle Timeline Figure.

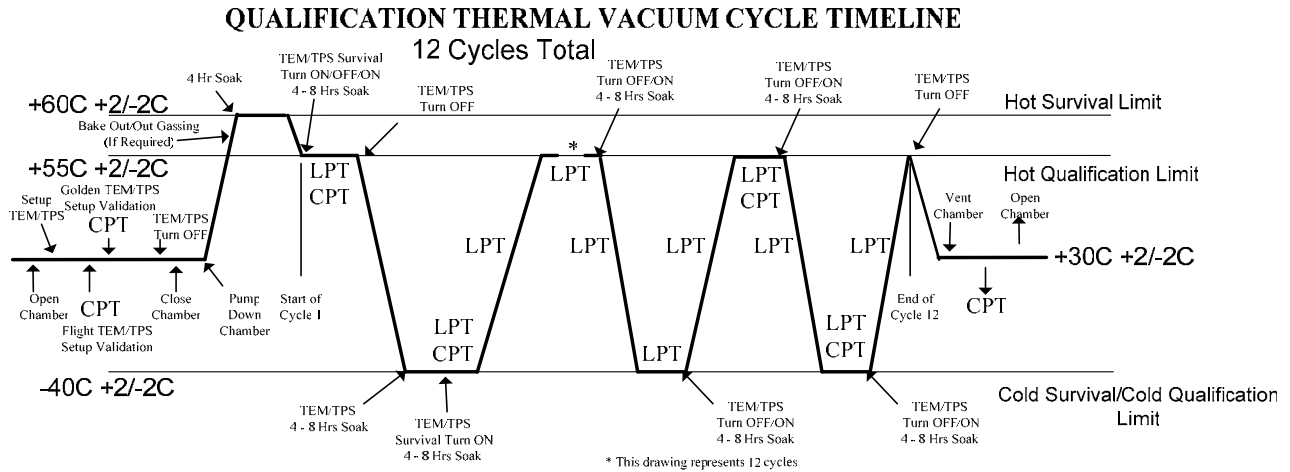

Figure 3. Qualification Thermal Vacuum Cycle Timeline

Note: When two TEM/TPS assemblies are tested both test setups must meet the testing requirements before proceeding.

- 1) Notify the QAE to witness the qualification test. **Record** per the data sheet.
- 2) Verify that section 5.2 has been performed.
- 3) During the execution of this procedure, the operator will be presented with prompts by the DAS test software. These prompts are of the following types:
 - a) “OK to Start Temperature Transition”: Selecting OK on this prompt will initiate the temperature transition in the sequence and will in most cases perform the required 4 hour soak at the destination plateau.
 - b) “Perform Electrical Test”: The operator is to perform the required electrical testing, CPT, LPT, Power ON and OFF, and etc., prior to selecting OK for this prompt.

5.3.2.1 Start of the Qualification Hot Survival Temperature Limit Test

This section performs the transition from ambient temperature to hot survival temperature and performs a 4 hour soak at the hot survival temperature. The thermal chamber pressure is below 2×10^{-5} prior to starting the transition. There may be a slight increase in chamber pressure as the TEM/TPS outgassing occurs during bake out which is acceptable as long as the TEM/TPS is not powered on. The TEM/TPS unit is to remain off during this transition to hot survival and during the soak period. The TEM/TPS is not to exceed the hot survival temperature limit. The start of the soak duration commences when the TEM/TPS stability measured at TC5 and TC6 is < 3 degrees C per hour. TEM/TPS bakeout will be performed at this temperature to accelerate the outgassing of the equipment. Outgassing is complete when the thermal vacuum chamber pressure is equal to the pressure that was recorded prior to the transition to hot survival.

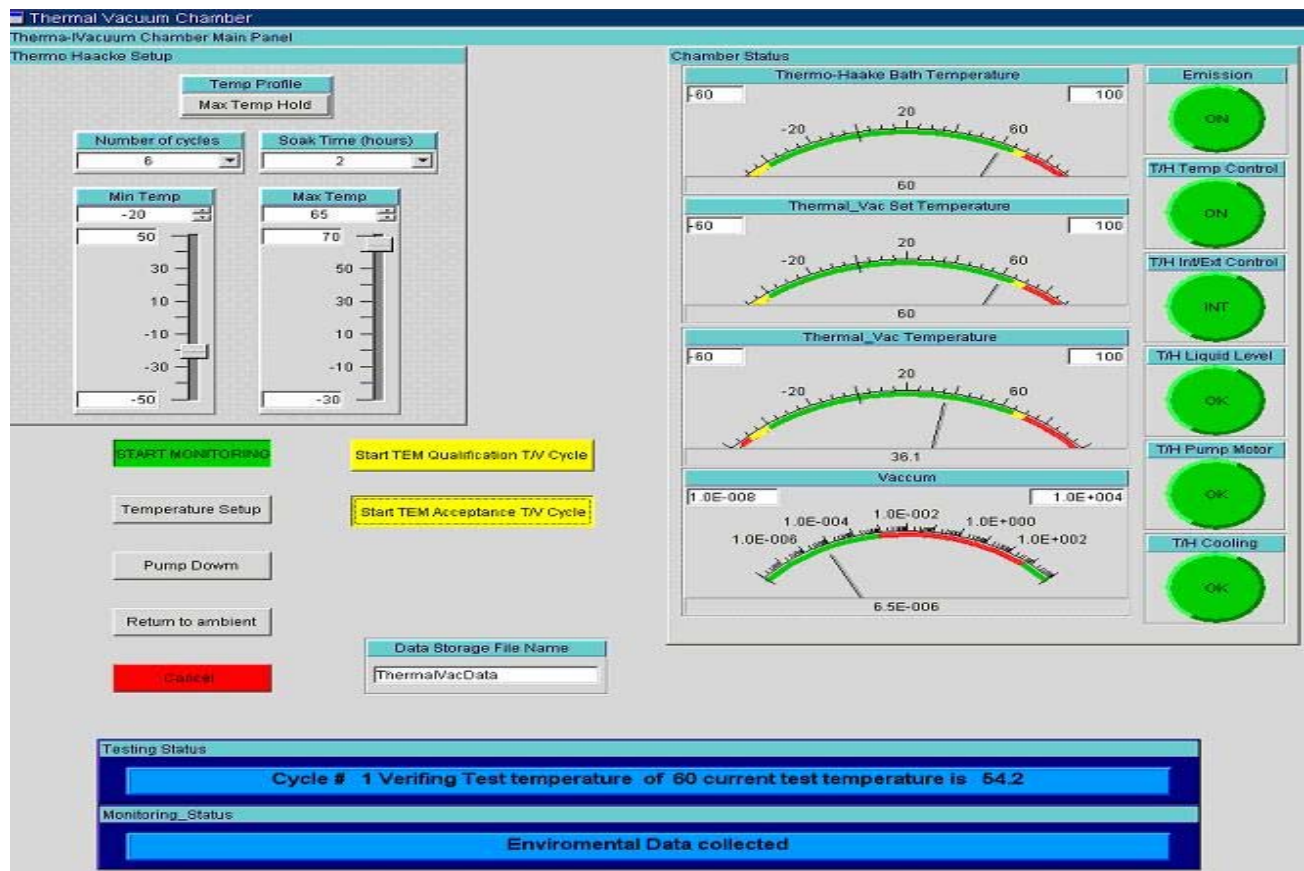

Figure 4. TV Chamber Main Panel

CAUTION: During the transition the operator is to monitor temperature transition to ensure that the target temperature is not exceeded.

- 1) Verify the TEM/TPS is powered OFF as defined in Appendix C. **Record** per the data sheet.
- 2) On the TV Chamber Main Panel, click on "OK to Start Temperature Transition" button. This will initiate the temperature transition and perform a 4 hour soak at the plateau. Refer to the TV Chamber Main Panel Figure.
- 3) Record temperature every 10 minutes. Continue until the message window at the bottom of the TV Chamber Main Panel displays the test temperature soak time.

5.3.2.2 Soaking at Qualification Hot Survival Temperature Limit

This section verifies the completion of the temperature soak at the hot survival temperature.

CAUTION: Respond to the “Verify End of Bakeout” prompt only when directed to by this procedure.

- 1) Monitor the message windows for soaking at the qualification hot survival temperature and soak time.
- 2) Upon receipt of the prompt “Verify End of Bakeout”, review the recorded environmental profiles (CVS file), verify the following:
 - a) Temperature of the TEM/TPS (thermo couplers TC 5 and TC 6) is +60 degrees C +2/-2C. **Record** the minimum and maximum temperatures per the data sheet.
 - b) The TEM/TPS soaked for 4 hours. **Record** per the data sheet.
 - c) Pressure is less than 5×10^{-5} Torr. **Record** the maximum pressure per the data sheet.

CAUTION: Consult with contamination engineer to verify the end of bakeout. Only at his direction will you initiate the transition to the hot qualification temperature.

- d) Verify the contamination engineer ends the bakeout. **Record** per the data sheet.

Note: When two TEM/TPS assemblies are tested both test setups must meet the testing requirements before proceeding.

- 3) At the prompt "click on "OK to start transition".

5.3.2.3 Transition to Qualification Hot Temperature Limit

This section performs the temperature transition from hot survival to hot qualification temperature. The thermal chamber pressure is to remain below 5×10^{-5} during this transition. The TEM/TPS unit is to remain off during this transition. The temperature ramp rate of the TEM/TPS is to be monitored to ensure that the maximum rate is not exceeded.

- 1) Record temperature every 10 minutes. Continue until the message window at the bottom of the TV Chamber Main Panel displays the qualification 55 deg. C temperature testing.

5.3.3 Qualification Test for Cycle 1

5.3.3.1 Hot Qualification Turn ON Test for First Cycle

This section performs the TEM/TPS turn on at hot qualification temperature. This is the first instance of the unit being powered on under vacuum at hot temperature. Successful turn on is required and any anomalous results are to be recorded.

- 1) Popup window "Perform Electrical Test" appears.
- 2) Review the recorded environmental profiles (CVS file). Verify the following:
- 3) Temperature at the TEM/TPS (thermo couplers TC 5 and TC 6) is +55 degrees C +2/-2C.
Record per the data sheet.

Note: When two TEM/TPS assemblies are tested both test setups must meet the testing requirements before proceeding.

- 4) Perform the following:
 - a) Turn the power ON to the TEM/TPS as defined in Appendix C. **Record** per the data sheet.
 - b) Turn power OFF to the TEM/TPS as defined in Appendix C. **Record** per the data sheet.
 - c) Turn power ON to the TEM/TPS as defined in Appendix C. **Record** per the data sheet.
 - d) Start a single LPT as defined in Appendix C.
 - e) At LPT Test Station, read the number of errors on the display and record on the data sheet.
 - f) Initiate the continuous LPT as defined in Appendix C.
 - g) Click on "OK" button.
- 5) At prompt "OK to Start Dwell" click on the OK button.

5.3.3.2 Soaking at Hot Qualification Temperature Limit Test for First Cycle

This section performs the temperature soak at the hot qualification temperature. The TEM TPS is to remain on during this soak. A continuous Limited Performance Test (LPT) will be performed during the temperature soak.

- 1) Upon receipt of the prompt “Perform Electrical Test”, perform the steps below:
- 2) At LPT Test Station, read the number of errors on the display and **record** on the data sheet.
- 3) Review the recorded environmental profiles (CVS file). Verify the following:
 - a) Temperature of the TEM/TPS (thermocouples TC 5 and TC6) is +55 degrees C +2/-2C. **Record** minimum and maximum temperatures per the data sheet.
 - b) The TEM/TPS soaked for minimum of 4 hours to a maximum of 8 hours. **Record** per the data sheet.
 - c) Pressure is less than 5×10^{-5} Torr. **Record** the maximum pressure per the data sheet.

Note: When two TEM/TPS assemblies are tested both test setups must meet the testing requirements before proceeding.

5.3.3.3 End of Soak CPT Test at Hot Qualification Temperature Limit for the First Cycle

This section performs a CPT at hot qualification temperature, after the required soak duration has been completed.

- 1) Perform one Comprehensive Performance Test at 20MHz, 14MHz, and, 22Mhz as defined in the Appendix C. **Record** per the data sheet.
- 2) Turn the power OFF to the TEM/TPS as defined in Appendix C. **Record** per the data sheet.
- 3) Select OK on the “Perform Electrical Test” prompt.

5.3.3.4 Start of the Transition to Cold Survival Temperature Limit Test for First Cycle

This section performs the temperature transition from hot qualification to cold survival temperature. The thermal chamber pressure is to remain below 5×10^{-5} during this transition. The TEM/TPS is to remain powered off during this transition.

- 1) Upon receipt of prompt “OK to Start Transition”, click the OK button.
- 2) Record temperature every 10 minutes. Continue until the message window at the bottom of the TV Chamber Main Panel displays the test temperature soak time.

5.3.3.5 Soaking at Qualification Cold Survival Temperature Limit for First Cycle

- 1) Upon receipt of the prompt “Perform Electrical Test”, review the recorded environmental profiles (CVS file), verify the following:
 - a) Temperature of the TEM/TPS (thermo couplers TC 5 and TC 6) is -40 degrees C ± 2 degrees C. **Record** per the data sheet. **Record** the minimum and maximum temperatures per the data sheet.
 - b) The TEM/TPS soaked for 4 hours. **Record** per the data sheet.
 - c) Pressure is less than 5×10^{-5} Torr. **Record** the maximum pressure per the data sheet.

Note: When two TEM/TPS assemblies are tested both test setups must meet the testing requirements before proceeding.

5.3.3.6 Cold Survival Turn ON Test for First Cycle

This section performs the TEM/TPS turn on at cold survival temperature. This is the first instance of the unit being powered on under vacuum at cold temperature. Successful turn on is required and any anomalous results are to be recorded.

- 1) Perform the following:
 - a) Turn the power ON to the TEM/TPS as defined in Appendix C. **Record** per the data sheet.
 - b) Start a single LPT as defined in Appendix C.
 - c) At LPT Test Station, read the number of errors on the display and record on the data sheet.
 - d) Start a continuous LPT as defined in Appendix C.
 - e) Click on “OK” button.

5.3.3.7 Transition from Cold Survival to Cold Qualification Temperature for First Cycle

This section performs the temperature transition from cold survival to cold qualification temperature. The thermal chamber pressure is to remain below 5×10^{-5} during this transition. The TEM/TPS unit is to remain on during this transition. A continuous LPT is to be performed during the transition.

- 1) Upon receipt of prompt “OK to Start Transition”, click the OK button.
- 2) Record temperature every 10 minutes. Continue until the message window at the bottom of the TV Chamber Main Panel displays the test temperature soak time.

5.3.3.8 Soaking at Qualification Cold Temperature Limit Test for First Cycle

This section performs the temperature soak at the cold qualification temperature. The TEM TPS is to remain on during this soak. A continuous Limited Performance Test (LPT) will be performed during the temperature soak.

- 1) Upon receipt of the prompt “Perform Electrical Test”, perform the steps below:
- 2) At LPT Test Station, read the number of errors on the display and record on the data sheet.
- 3) Review the recorded environmental profiles (CVS file). Verify the following:
 - a) Temperature of the TEM/TPS (thermo couplers TC 5 and TC 6) is -40 degrees C +2/-2C. **Record** per the data sheet. **Record** minimum and maximum temperatures per the data sheet.
 - b) The TEM/TPS soaked for minimum of 4 hours to a maximum of 8 hours. **Record** per the data sheet.
 - c) Pressure is less than 5×10^{-5} Torr. **Record** the maximum pressure per the data sheet.

Note: When two TEM/TPS assemblies are tested both test setups must meet the testing requirements before proceeding.

5.3.3.9 End of Soak CPT Test at Cold Qualification Temperature Limit for the First Cycle

This section performs a CPT at hot qualification temperature, after the required soak duration has been completed.

- 1) Perform one CPT as defined in Appendix C. **Record** per the data sheet.
- 2) Start continuous LPT as defined in Appendix C.
- 3) Select OK on the “Perform Electrical Test” prompt.

5.3.3.10 Start of the Transition from Cold Qualification to Hot Qualification Temperature

This section performs the temperature transition from cold qualification to hot qualification temperature. The thermal chamber pressure is to remain below 5×10^{-5} during this transition. The temperature ramp rate of the TEM/TPS is to be monitored to ensure that the maximum rate is not exceeded. The TEM/TPS is to remain powered off during this transition.

- 1) Upon receipt of prompt “OK to Start Transition”, click the OK button.
- 2) Record temperature every 10 minutes. Continue until the message window at the bottom of the TV Chamber Main Panel displays the test temperature soak time.

5.3.4 Qualification Test for Cycle 2 through 11

This section is to be performed and repeated for qualification test cycles 2 through 11.

5.3.4.1 Soaking at Qualification Low Temperature Limit Test for Cycle 2 through 11

This section performs the temperature soak at the hot qualification temperature. The TEM/TPS is to remain on during this soak. A continuous Limited Performance Test (LPT) will be performed during the temperature soak.

- 1) **Record** Cycle Number on data sheet.
- 2) Upon receipt of the prompt “Perform Electrical Test”, perform the steps below:
- 3) At LPT Test Station, read the number of errors on the display. **Record** per the data sheet.
- 4) Review the recorded environmental profiles (CVS file). Verify the following:
 - a) Temperature of the TEM/TPS (thermo couplers TC 5 and TC 6) is 55 degrees C +/- 2C. **Record** minimum and maximum temperatures per the data sheet.
 - b) The TEM/TPS soaked for minimum of 4 hours to a maximum of 8 hours. **Record** per the data sheet.
 - c) Pressure is less than 5×10^{-5} Torr. **Record** the maximum pressure per the data sheet.

Note: When two TEM/TPS assemblies are tested both test setups must meet the testing requirements before proceeding.

5.3.4.2 Qualification Hot Temperature Limit Turn ON for Cycle 2 through 11

This section performs the power turn on demonstration for the hot qualification temperature.

Successful turn ON of the TEM/TPS is required and any anomalous behavior is to be recorded.

- 1) Turn the power OFF to the TEM/TPS per Appendix C. **Record** per data sheet.
- 2) Turn the power ON to the TEM/TPS per Appendix C. **Record** per data sheet.

Hard copies of this document are for REFERENCE ONLY and should not be considered the latest revision.

5.3.4.3 End of Soak LPT Test at Qualification Hot Temperature for Cycle 2 through 11

This section performs a LPT at hot qualification temperature, after the required soak duration has been completed.

- 1) Perform one LPT as defined in Appendix C. **Record** per the data sheet.
- 2) Initiate continuous LPT as defined in Appendix C.
- 3) Click “OK”.

5.3.4.4 Start of the Transition from Hot Qualification to Cold Qualification Temperature

This section performs the temperature transition from hot qualification to cold qualification temperature. The thermal chamber pressure is to remain below 5×10^{-5} during this transition. The temperature ramp rate of the TEM/TPS is to be monitored to ensure that the maximum rate is not exceeded.

- 1) Upon receipt of prompt “OK to Start Transition”, click the OK button.
- 2) Record temperature every 10 minutes. Continue until the message window at the bottom of the TV Chamber Main Panel displays the test temperature soak time.

5.3.4.5 Soaking at Cold Qualification Temperature Limit Test for Cycle 2 through 11

This section performs the temperature soak at the cold qualification temperature. The TEM/TPS is to remain on during this soak. A continuous Limited Performance Test (LPT) will be performed during the temperature soak.

- 1) Upon receipt of the prompt “Perform Electrical Test”, perform the steps below.
- 2) At LPT Test Station, read the number of errors on the display and record on the data sheet.
- 3) Review the recorded environmental profiles (CVS file). Verify the following.
 - a) Temperature of the TEM/TPS (thermo couplers TC 5 and TC 6) is -40 degrees C +2/-2C. **Record** minimum and maximum temperatures per the data sheet.
 - b) The TEM/TPS soaked for minimum of 4 hours to a maximum of 8 hours. **Record** per the data sheet.
 - c) Pressure is less than 5×10^{-5} Torr. **Record** the maximum pressure per the data sheet.

Note: When two TEM/TPS assemblies are tested both test setups must meet the testing requirements before proceeding.

5.3.4.6 Cold Qualification Temperature Limit Turn ON Test for Cycle 2 through 11

This section performs the power turn on demonstration for the cold qualification temperature. Successful turn on of the TEM/TPS is required and any anomalous behavior is to be recorded.

- 1) Turn the power OFF to the TEM/TPS per Appendix C. **Record** per data sheet.
- 2) Turn the power ON to the TEM/TPS per Appendix C. **Record** per data sheet.

5.3.4.7 End of Soak LPT Test at Cold Qualification Temperature for Cycle 2 through 11

This section performs a LPT at cold qualification temperature, after the required soak duration has been completed.

- 1) Perform one LPT as defined in Appendix C. **Record** per the data sheet.
- 2) Initiate continuous LPT as defined in Appendix C.
- 3) Click “OK”.

5.3.4.8 Start of the Transition from Cold Qualification to Hot Qualification Temperature

This section performs the temperature transition from cold qualification to hot qualification temperature. The thermal chamber pressure is to remain below 5×10^{-5} during this transition.

- 1) Upon receipt of prompt “OK to Start Transition”, click the "OK" button.
- 2) Record temperature every 10 minutes. Continue until the message window at the bottom of the TV Chamber Main Panel displays the test temperature soak time.

5.3.5 Qualification Test for Cycle 12

This section is to be performed for qualification test cycle 12.

5.3.5.1 Soaking at Hot Qualification Temperature Limit Test for Cycle 12

This section performs the temperature soak at the hot qualification temperature. The TEM/TPS is to remain on during this soak. A continuous Limited Performance Test (LPT) is performed during the temperature soak.

- 1) Upon receipt of the prompt “Perform Electrical Test”, perform the steps below.
- 2) At LPT Test Station, read the number of errors on the display. **Record** per the data sheet.
- 3) Review the recorded environmental profiles (CVS file). Verify the following:
 - a) Temperature of the TEM/TPS (thermo couplers TC 5 and TC 6) is 55 degrees C +/- 2C. **Record** per the data sheet.
 - b) The TEM/TPS soaked for minimum of 4 hours to a maximum of 8 hours. Record per the data sheet.
 - c) Pressure is less than 5×10^{-5} Torr. Record the maximum pressure per the data sheet.

Note: When two TEM/TPS assemblies are tested both test setups must meet the testing requirements before proceeding.

5.3.5.2 Hot Qualification Temperature Limit Turn ON Test for Cycle 12

This section performs the power turn on demonstration for the hot qualification temperature. Successful turn on of the TEM/TPS is required and any anomalous behavior is to be recorded.

- 1) Turn the power OFF to the TEM/TPS per Appendix C. Record per data sheet.
- 2) Turn the power ON to the TEM/TPS per Appendix C. Record per data sheet.

5.3.5.3 End of Soak CPT Test at Hot Qualification Temperature

This section performs a CPT at hot qualification temperature, after the required soak duration has been completed.

- 1) Perform a partial CPT at 20MHz, 14MHz, and 22MHz as defined in Appendix C. **Record** per the data sheet.
- 2) Initiate continuous LPT as defined in Appendix C.
- 3) Click “OK”

5.3.5.4 Start of the Transition from Hot Qualification to Cold Qualification Temperature

This section performs the temperature transition from hot qualification to cold qualification temperature. The thermal chamber pressure is to remain below 5×10^{-5} during this transition. The temperature ramp rate of the TEM/TPS is to be monitored to ensure that the maximum rate is not exceeded.

- 1) Upon receipt of prompt “OK to Start Transition”, click the OK button.
- 2) Record temperature every 10 minutes. Continue until the message window at the bottom of the TV Chamber Main Panel displays the test temperature soak time.

5.3.5.5 Soaking at Cold Qualification Temperature Limit Test for Cycle 12

This section performs the temperature soak at the cold qualification temperature. The TEM/TPS is to remain on during this soak. A continuous Limited Performance Test (LPT) will be performed during the temperature soak.

- 1) Upon receipt of the prompt “Perform Electrical Test”, perform the steps below:
- 2) At LPT Test Station, read the number of errors on the display and record on the data sheet.
- 3) Review the recorded environmental profiles (CVS file). Verify the following:
 - a) Temperature of the TEM/TPS (thermo couplers TC 5 and TC 6) is -40 degrees C +2/-2C. **Record** minimum and maximum temperatures per the data sheet.
 - b) The TEM/TPS soaked for minimum of 4 hours to a maximum of 8 hours. **Record** per the data sheet.
 - c) Pressure is less than 5×10^{-5} Torr. **Record** the maximum pressure per the data sheet.

Note: When two TEM/TPS assemblies are tested both test setups must meet the testing requirements before proceeding.

5.3.5.6 Cold Qualification Temperature Limit Turn ON Test for Cycle 12

This section performs the power turn on demonstration for the cold qualification temperature. Successful turn on of the TEM/TPS is required and any anomalous behavior is to be recorded.

- 1) Turn the power OFF to the TEM/TPS per Appendix C. Record per data sheet.
- 2) Turn the power ON to the TEM/TPS per Appendix C. Record per data sheet.

5.3.5.7 End of Soak CPT Test at Cold Qualification Temperature for Cycle 12

This section performs a CPT at cold qualification temperature, after the required soak duration has been completed.

- 1) Perform one Comprehensive Performance Test as defined in Appendix C. **Record** per the data sheet.
- 2) Initiate continuous LPT as defined in Appendix C.
- 3) Click “OK”.

5.3.5.8 Start of the Transition from Cold Qualification to Hot Qualification Temperature

This section performs the temperature transition from cold qualification to hot qualification temperature. The thermal chamber pressure is to remain below 5×10^{-5} during this transition. The temperature ramp rate of the TEM/TPS is to be monitored to ensure that the maximum rate is not exceeded.

- 1) Upon receipt of prompt “OK to Start Transition”, click the OK button.
- 2) Record temperature every 10 minutes. Continue until the message window at the bottom of the TV Chamber Main Panel displays the test temperature soak time.

5.3.6 Shutdown Cycle of the Qualification Test

This section is to be performed for qualification test at the end of cycle 12.

5.3.6.1 Short Soak at Hot Qualification Temperature Limit at the End of Cycle 12

This section performs the temperature soak at the hot qualification temperature. The TEM/TPS is to remain on during this soak. A continuous Limited Performance Test (LPT) will be performed during the temperature soak.

- 1) Upon receipt of the prompt “Turn TEM/TPS OFF”, perform the following steps.
- 2) At LPT Test Station, read the number of errors on the display. **Record** on the data sheet.
- 3) Review the recorded environmental profiles (CVS file). Verify the following:
 - a) Temperature of the TEM/TPS (thermo couplers TC 5 and TC 6) is +55 degrees C +2/-2C. **Record** minimum and maximum temperatures per the data sheet.
 - b) Pressure is less than 5×10^{-5} Torr. **Record** the maximum pressure per the data sheet.

Note: When two TEM/TPS assemblies are tested both test setups must meet the testing requirements before proceeding.

- 4) Turn the power OFF to the TEM/TPS as defined in Appendix C. **Record** per data sheet.
- 5) Click OK.

5.3.6.2 Start of Shutdown Cycle of the Qualification Test

- 1) Upon receipt of the prompt "OK to Transition" perform the following:
- 2) Notify the Test Director the Qualification Thermal Vacuum Performance Testing is complete and ready to bring chamber to ambient temperature. Record per the data sheet.
- 3) Click OK and wait for the prompt "Complete Qualification Temp. Testing".
- 4) Monitor temperature of the TEM/TPS (thermo couples TC 5 and TC 6) is +30 degree +2/-2 C. Record per the data sheet.

Note: When two TEM/TPS assemblies are tested both test setups must meet the testing requirements before proceeding.

- 5) Proceed to the section Shutdown of Chamber within this test procedure.

5.3.7 Acceptance Start Test

When perform the following test refer to the Acceptance Thermal Vacuum Cycle Timeline Figure.

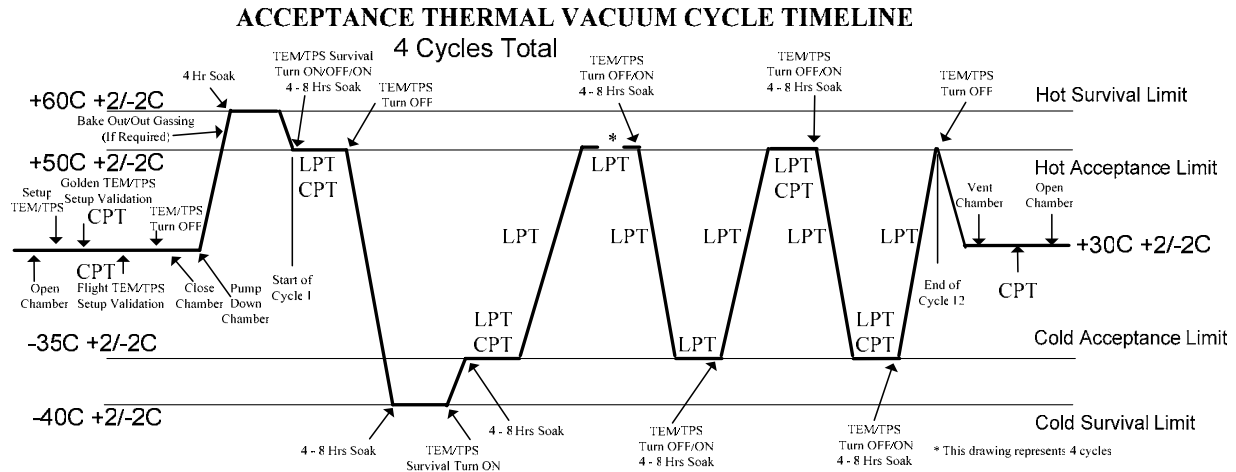

Figure 5. Acceptance Thermal Vacuum Cycle Timeline

- 1) Notify the QAE to witness the acceptance test. **Record** per the data sheet.
- 2) Verify that section 5.2 has been performed.
- 3) During the execution of this procedure, the operator will be presented with prompts by the DAS test software. These prompts are of the following types:
 - ◆ “OK to Start Temperature Transition”: Selecting OK on this prompt will initiate the temperature transition in the sequence and will perform the required 4 hour soak at the destination plateau.
 - ◆ “Perform Electrical Test”: The operator is to perform the required electrical testing, CPT, LPT, Power ON and OFF, and etc., prior to selecting OK for this prompt.

Note: When two TEM/TPS assemblies are tested both test setups must meet the testing requirements before proceeding.

Start of the Acceptance Hot Survival Temperature Limit Test for First Cycle

This section performs the transition from ambient temperature to hot survival temperature and performs a 4 hour soak at the hot survival temperature. The thermal chamber pressure is below 2×10^{-5} prior to starting the transition. There may be a slight increase in chamber pressure as the TEM/TPS outgassing occurs during bake out which is acceptable as long as the TEM/TPS is not powered on. The TEM/TPS unit is to remain off during this transition to hot survival and during the soak period. The temperature ramp rate of the TEM/TPS is to be monitored to ensure that the maximum rate is not exceeded. The TEM/TPS is not to exceed the hot survival temperature limit. The start of the soak duration commences when the TEM/TPS stability measured at TC5 and TC6 is < 3 degrees C per hour. TEM/TPS bakeout will be performed at this temperature to accelerate the outgassing of the equipment. Outgassing is complete when the thermal vacuum chamber pressure is equal to the pressure that was recorded prior to the transition to hot survival.

CAUTION: During the transition the operator is to monitor temperature transition to ensure that the target temperature is not exceeded.

- 1) Verify the TEM/TPS is powered OFF. **Record** per the data sheet.
- 2) On the TV Chamber Main Panel, click on "OK to Start Transition" button. This will initiate the temperature transition and perform a 4 hour soak at the plateau.
- 3) Record temperature every 10 minutes. Continue until the message window at the bottom of the TV Chamber Main Panel displays the test temperature soak time.

5.3.7.1 Completion of Soaking at Acceptance Hot Survival Temperature Limit

This section verifies the completion of the temperature soak at the hot survival temperature.

- 1) Monitor the message windows for soaking at the acceptance hot survival temperature and soak time.

CAUTION: Respond to the “Verify End of Bakeout” prompt only when directed to by this procedure.

- 2) Upon receipt of the prompt “Verify End of Bakeout”, review the recorded environmental profiles (CVS file), verify the following:
 - a) Temperature of the TEM/TPS (thermo couplers TC 5 and TC 6) is +60 degrees C +2/-2C. **Record** the minimum and maximum temperatures per the data sheet.
 - b) The TEM/TPS soaked for 4 hours. **Record** per the data sheet.
 - c) Pressure is less than 5×10^{-5} Torr. **Record** the maximum pressure per the data sheet.

CAUTION: Consult with contamination engineer to verify the end of bakeout. Only at his direction will you initiate the transition to the hot acceptance temperature.

- d) Verify the contamination engineer ends the bakeout. **Record** per the data sheet.

Note: When two TEM/TPS assemblies are tested both test setups must meet the testing requirements before proceeding.

- 3) At the prompt "click on "OK to start transition".

5.3.7.2 Transition to Acceptance Hot Temperature Limit Test Cycle

This section performs the temperature transition from hot survival to hot acceptance temperature. The thermal chamber pressure is to remain below 5×10^{-5} during this transition. The TEM/TPS unit is to remain off during this transition. The temperature ramp rate of the TEM/TPS is to be monitored to ensure that the maximum rate is not exceeded.

- 1) Record temperature every 10 minutes. Continue until the message window at the bottom of the TV Chamber Main Panel displays the acceptance 50 deg. C temperature testing.

5.3.8 Acceptance Test for Cycle 1

5.3.8.1 Hot Acceptance Turn ON Test for First Cycle

This section performs the TEM/TPS turn on at hot acceptance temperature. This is the first instance of the unit being powered on under vacuum at hot temperature. Successful turn on is required and any anomalous results are to be recorded.

- 1) Popup window "Perform Electrical Test" appears.
- 2) Review the recorded environmental profiles (CVS file). Verify the following:
 - a) Temperature at the TEM/TPS (thermo couplers TC 5 and TC 6) is +50 degrees C +/- 2C. **Record** per the data sheet.
- 3) Perform the following:
 - a) Turn power ON to the TEM/TPS as defined in Appendix C. **Record** per the data sheet.
 - b) Turn power OFF to the TEM/TPS as defined in Appendix C. **Record** per the data sheet.
 - c) Turn power ON to the TEM/TPS as defined in Appendix C. **Record** per the data sheet.
 - d) Start a single LPT as defined in Appendix C.
 - e) At LPT Test Station, read the number of errors on the display and record on the data sheet.
 - f) Initiate the continuous LPT test. The LPT as defined in Appendix C.

Note: When two TEM/TPS assemblies are tested both test setups must meet the testing requirements before proceeding.

- g) Click on "OK" button.
- 4) At prompt "OK to Start Dwell" click on the "OK" button.

5.3.8.2 Soaking at Hot Acceptance Temperature Limit Test for First Cycle

This section performs the temperature soak at the hot acceptance temperature. The TEM TPS is to remain on during this soak. A continuous Limited Performance Test (LPT) will be performed during the temperature soak.

- 1) Upon receipt of the prompt “Perform Electrical Test”, perform the steps below:
- 2) At LPT Test Station, read the number of errors on the display and **record** on the data sheet.
- 3) Review the recorded environmental profiles (CVS file). Verify the following:
 - a) Temperature of the TEM/TPS (thermocouples TC 5 and TC6) is +50 degrees C +2/-2C. **Record** minimum and maximum temperatures per the data sheet.
 - b) The TEM/TPS soaked for minimum of 4 hours to a maximum of 8 hours. **Record** per the data sheet.
 - c) Pressure is less than 5×10^{-5} Torr. **Record** the maximum pressure per the data sheet.

Note: When two TEM/TPS assemblies are tested both test setups must meet the testing requirements before proceeding.

5.3.8.3 End of Soak CPT Test at Hot Acceptance Temperature Limit for the First Cycle

This section performs a CPT at hot acceptance temperature, after the required soak duration has been completed.

- 1) Perform one Comprehensive Performance Test at 20MHz, 14MHz, and 22 MHz as defined in the Appendix C. **Record** per the data sheet.
- 2) Turn the power OFF to the TEM/TPS as defined in Appendix C. **Record** per the data sheet.
- 3) Select OK on the “Perform Electrical Test” prompt.

5.3.8.4 Start of the Transition to Cold Survival Temperature Limit Test for First Cycle

This section performs the temperature transition from hot acceptance to cold survival temperature. The thermal chamber pressure is to remain below 5×10^{-5} during this transition. The temperature ramp rate of the TEM/TPS is to be monitored to ensure that the maximum rate is not exceeded. The TEM/TPS is to remain powered off during this transition.

- 1) Upon receipt of prompt “OK to Start Transition”, click the OK button.
- 2) Record temperature every 10 minutes. Continue until the message window at the bottom of the TV Chamber Main Panel displays the test temperature soak time.

5.3.8.5 Soaking at Qualification Cold Survival Temperature Limit for First Cycle

- 1) Upon receipt of the prompt “Perform Electrical Test”, review the recorded environmental profiles (CVS file), verify the following:
 - a) Temperature of the TEM/TPS (thermo couplers TC 5 and TC 6) is -40 degrees C +2/-2C. **Record** per the data sheet. **Record** the minimum and maximum temperatures per the data sheet.
 - b) The TEM/TPS soaked for 4 hours. **Record** per the data sheet.
 - c) Pressure is less than 5×10^{-5} Torr. **Record** the maximum pressure per the data sheet.

Note: When two TEM/TPS assemblies are tested both test setups must meet the testing requirements before proceeding.

5.3.8.6 Cold Survival Turn ON Test for First Cycle

This section performs the TEM/TPS turn on at cold survival temperature. This is the first instance of the unit being powered on under vacuum at cold temperature. Successful turn on is required and any anomalous results are to be recorded.

1) Perform the following:

- a) Turn the power ON to the TEM/TPS as defined in Appendix C. **Record** per the data sheet.
- b) Start a single LPT as defined in Appendix C.
- c) At LPT Test Station, read the number of errors on the display and record on the data sheet.

Note: When two TEM/TPS assemblies are tested both test setups must meet the testing requirements before proceeding.

- d) Start a continuous LPT as defined in Appendix C.
- e) Click on “OK” button.

5.3.8.7 Transition from Cold Survival to Cold Acceptance Temperature for First Cycle

This section performs the temperature transition from cold survival to cold acceptance temperature. The thermal chamber pressure is to remain below 5×10^{-5} during this transition. The TEM/TPS unit is to remain on during this transition. A continuous LPT is to be performed during the transition.

- 1) Upon receipt of prompt “OK to Start Transition”, click the OK button.
- 2) Record temperature every 10 minutes. Continue until the message window at the bottom of the TV Chamber Main Panel displays the test temperature soak time.

5.3.8.8 Soaking at Acceptance Cold Temperature Limit Test for First Cycle

This section performs the temperature soak at the cold acceptance temperature. The TEM TPS is to remain on during this soak. A continuous Limited Performance Test (LPT) will be performed during the temperature soak.

- 1) Upon receipt of the prompt “Perform Electrical Test”, perform the steps below:
- 2) At LPT Test Station, read the number of errors on the display and record on the data sheet.
- 3) Review the recorded environmental profiles (CVS file). Verify the following:
 - a) Temperature of the TEM/TPS (thermo couplers TC 5 and TC 6) is -35 degrees C \pm 2C. **Record** per the data sheet. **Record** minimum and maximum temperatures per the data sheet.
 - b) The TEM/TPS soaked for minimum of 4 hours to a maximum of 8 hours. **Record** per the data sheet.
 - c) Pressure is less than 5×10^{-5} Torr. **Record** the maximum pressure per the data sheet.

Note: When two TEM/TPS assemblies are tested both test setups must meet the testing requirements before proceeding.

5.3.8.9 End of Soak CPT Test at Cold Acceptance Temperature Limit for the First Cycle

This section performs a CPT at cold acceptance temperature, after the required soak duration has been completed.

- 1) Perform one Comprehensive Performance Test at 20MHz, 14MHz, and 22MHz as defined in Appendix C. **Record** per the data sheet.
- 2) Start continuous LPT as defined in Appendix C.
- 3) Select OK on the “Perform Electrical Test” prompt.

5.3.8.10 Start of the Transition from Cold Acceptance to Hot Acceptance Temperature

This section performs the temperature transition from cold acceptance to hot acceptance temperature. The thermal chamber pressure is to remain below 5×10^{-5} during this transition. The temperature ramp rate of the TEM/TPS is to be monitored to ensure that the maximum rate is not exceeded. The TEM/TPS is to remain powered off during this transition.

- 1) Upon receipt of prompt “OK to Start Transition”, click the OK button.
- 2) Record temperature every 10 minutes. Continue until the message window at the bottom of the TV Chamber Main Panel displays the test temperature soak time.

5.3.9 Acceptance Test for Cycle 2-3

This section is to be performed and repeated for acceptance test cycles 2 and 3.

5.3.9.1 Soaking at Acceptance Cold Temperature Limit Test for Cycle 2 and 3

This section performs the temperature soak at the cold acceptance temperature. The TEM/TPS is to remain on during this soak. A continuous Limited Performance Test (LPT) will be performed during the temperature soak.

- 1) **Record** Cycle Number on data sheet.
- 2) Upon receipt of the prompt “Perform Electrical Test”, perform the steps below:
- 3) At LPT Test Station, read the number of errors on the display. **Record** per the data sheet.
- 4) Review the recorded environmental profiles (CVS file). Verify the following:
 - a) Temperature of the TEM/TPS (thermo couplers TC 5 and TC 6) is 50 degrees C +/- 2C. **Record** minimum and maximum temperatures per the data sheet.
 - b) The TEM/TPS soaked for minimum of 4 hours to a maximum of 8 hours. **Record** per the data sheet.
 - c) Pressure is less than 5×10^{-5} Torr. **Record** the maximum pressure per the data sheet.

Note: When two TEM/TPS assemblies are tested both test setups must meet the testing requirements before proceeding.

5.3.9.2 Acceptance Hot Temperature Limit Turn ON for Cycle 2 and 3

This section performs the power turn on demonstration for the hot acceptance temperature.

Successful turn ON of the TEM/TPS is required and any anomalous behavior is to be recorded.

- 1) Turn the power OFF to the TEM/TPS per Appendix C. **Record** per data sheet.
- 2) Turn the power ON to the TEM/TPS per Appendix C. **Record** per data sheet.

Hard copies of this document are for REFERENCE ONLY and should not be considered the latest revision.

5.3.9.3 End of Soak LPT Test at Acceptance Hot Temperature for Cycle 2 and 3

This section performs a LPT at hot acceptance temperature, after the required soak duration has been completed.

- 1) Perform one last Limited Performance Test as defined in Appendix C. **Record** per the data sheet.
- 2) Initiate continuous LPT as defined in Appendix C.
- 3) Click on “OK”.

5.3.9.4 Start of the Transition from Hot Acceptance to Cold Acceptance Temperature

This section performs the temperature transition from hot acceptance to cold acceptance temperature. The thermal chamber pressure is to remain below 5×10^{-5} during this transition. The temperature ramp rate of the TEM/TPS is to be monitored to ensure that the maximum rate is not exceeded.

- 1) Upon receipt of prompt “OK to Start Transition”, click the OK button.
- 2) Record temperature every 10 minutes. Continue until the message window at the bottom of the TV Chamber Main Panel displays the test temperature soak time.

5.3.9.5 Soaking at Cold Acceptance Temperature Limit Test for Cycle 2 and 3

This section performs the temperature soak at the cold acceptance temperature. The TEM/TPS is to remain on during this soak. A continuous Limited Performance Test (LPT) will be performed during the temperature soak.

- 1) Upon receipt of the prompt “Perform Electrical Test”, perform the steps below.
- 2) At LPT Test Station, read the number of errors on the display and record on the data sheet.
- 3) Review the recorded environmental profiles (CVS file). Verify the following.
 - a) Temperature of the TEM/TPS (thermo couplers TC 5 and TC 6) is -35 degrees C +2/-2C. **Record** minimum and maximum temperatures per the data sheet.
 - b) The TEM/TPS soaked for minimum of 4 hours to a maximum of 8 hours. **Record** per the data sheet.
 - c) Pressure is less than 5×10^{-5} Torr. **Record** the maximum pressure per the data sheet.

Note: When two TEM/TPS assemblies are tested both test setups must meet the testing requirements before proceeding.

5.3.9.6 Cold Acceptance Temperature Limit Turn ON Test for Cycle 2 and 3

This section performs the power turn on demonstration for the cold acceptance temperature. Successful turn on of the TEM/TPS is required and any anomalous behavior is to be recorded.

- 1) Turn the power OFF to the TEM/TPS per Appendix C. **Record** per data sheet.
- 2) Turn the power ON to the TEM/TPS per Appendix C. **Record** per data sheet.

5.3.9.7 End of Soak LPT Test at Cold Acceptance Temperature for Cycle 2 and 3

This section performs a LPT at cold acceptance temperature, after the required soak duration has been completed.

- 1) Perform one Limited Performance Test as defined in Appendix C. **Record** per the data sheet.
- 2) Initiate continuous LPT as defined in Appendix C.
- 3) Click on “OK”.

5.3.9.8 Start of the Transition from Cold Acceptance to Hot Acceptance Temperature

This section performs the temperature transition from cold acceptance to hot acceptance temperature. The thermal chamber pressure is to remain below 5×10^{-5} during this transition.

- 1) Upon receipt of prompt “OK to Start Transition”, click the OK button.
- 2) Record temperature every 10 minutes. Continue until the message window at the bottom of the TV Chamber Main Panel displays the test temperature soak time.

5.3.10 Acceptance Test for Cycle 4

This section is to be performed for acceptance test cycle 4.

5.3.10.1 Soaking at Hot Acceptance Temperature Limit Test for Cycle 4

This section performs the temperature soak at the hot acceptance temperature. The TEM/TPS is to remain on during this soak. A continuous Limited Performance Test (LPT) is performed during the temperature soak.

- 1) Upon receipt of the prompt “Perform Electrical Test”, perform the steps below.
- 2) At LPT Test Station, read the number of errors on the display. **Record** per the data sheet.
- 3) Review the recorded environmental profiles (CVS file). Verify the following:
 - a) Temperature of the TEM/TPS (thermo couplers TC 5 and TC 6) is 50 degrees C +2/-2C. **Record** per the data sheet.
 - b) The TEM/TPS soaked for minimum of 4 hours to a maximum of 8 hours. Record per the data sheet.
 - c) Pressure is less than 5×10^{-5} Torr. Record the maximum pressure per the data sheet.

Note: When two TEM/TPS assemblies are tested both test setups must meet the testing requirements before proceeding.

5.3.10.2 Hot Acceptance Temperature Limit Turn ON Test for Cycle 4

This section performs the power turn on demonstration for the hot acceptance temperature. Successful turn on of the TEM/TPS is required and any anomalous behavior is to be recorded.

- 1) Turn the power OFF to the TEM/TPS per Appendix C. Record per data sheet.
- 2) Turn the power ON to the TEM/TPS per Appendix C. Record per data sheet.

5.3.10.3 End of Soak CPT Test at Hot Acceptance Temperature

This section performs a CPT at hot acceptance temperature, after the required soak duration has been completed.

- 1) Perform a partial Comprehensive Performance Test at 20MHz, 14MHz, and 22MHz as defined in Appendix C. **Record** per the data sheet.
- 2) Initiate continuous LPT as defined in Appendix C.
- 3) Click on “OK”.

5.3.10.4 Start of the Transition from Hot Acceptance to Cold Acceptance Temperature for Cycle 4

This section performs the temperature transition from hot acceptance to cold acceptance temperature. The thermal chamber pressure is to remain below 5×10^{-5} during this transition. The temperature ramp rate of the TEM/TPS is to be monitored to ensure that the maximum rate is not exceeded.

- 1) Upon receipt of prompt “OK to Start Transition”, click the “OK” button.
- 2) Record temperature every 10 minutes. Continue until the message window at the bottom of the TV Chamber Main Panel displays the test temperature soak time.

5.3.10.5 Soaking at Cold Acceptance Temperature Limit Test for Cycle 4

This section performs the temperature soak at the cold acceptance temperature. The TEM/TPS is to remain on during this soak. A continuous Limited Performance Test (LPT) will be performed during the temperature soak.

- 1) Upon receipt of the prompt “Perform Electrical Test”, perform the steps below:
- 2) At LPT Test Station, read the number of errors on the display and record on the data sheet.
- 3) Review the recorded environmental profiles (CVS file). Verify the following:
 - a) Temperature of the TEM/TPS (thermo couplers TC 5 and TC 6) is -35 degrees C +2/-2C. **Record** minimum and maximum temperatures per the data sheet.
 - b) The TEM/TPS soaked for minimum of 4 hours to a maximum of 8 hours. **Record** per the data sheet.
 - c) Pressure is less than 5×10^{-5} Torr. **Record** the maximum pressure per the data sheet.

Note: When two TEM/TPS assemblies are tested both test setups must meet the testing requirements before proceeding.

5.3.10.6 Cold Acceptance Temperature Limit Turn ON Test for Cycle 4

This section performs the power turn on demonstration for the cold acceptance temperature. Successful turn on of the TEM/TPS is required and any anomalous behavior is to be recorded.

- 1) Turn the power OFF to the TEM/TPS per Appendix C. Record per data sheet.
- 2) Turn the power ON to the TEM/TPS per Appendix C. Record per data sheet.

5.3.10.7 End of Soak CPT Test at Cold Acceptance Temperature for Cycle 4

This section performs a CPT at cold acceptance temperature, after the required soak duration has been completed.

- 1) Perform one Comprehensive Performance Test at 20MHz, 14MHz, and 22MHz as defined in Appendix C. **Record** per the data sheet.
- 2) Initiate continuous LPT as defined in Appendix C.
- 3) Click on “OK”.

5.3.10.8 Start of the Transition from Cold Acceptance to Hot Acceptance Temperature for Cycle 4

This section performs the temperature transition from cold acceptance to hot acceptance temperature. The thermal chamber pressure is to remain below 5×10^{-5} during this transition. The temperature ramp rate of the TEM/TPS is to be monitored to ensure that the maximum rate is not exceeded.

- 1) Upon receipt of prompt “OK to Start Transition”, click the OK button.
- 2) Record temperature every 10 minutes. Continue until the message window at the bottom of the TV Chamber Main Panel displays the test temperature soak time.

5.3.11 Shutdown Cycle of the Acceptance Test

This section is to be performed for acceptance test at the end of cycle 4.

5.3.11.1 Short Soak at Hot Acceptance Temperature Limit at the End of Cycle 4

This section performs the temperature soak at the hot acceptance temperature. The TEM/TPS is to remain on during this soak. A continuous Limited Performance Test (LPT) will be performed during the temperature soak.

- 1) Upon receipt of the prompt “Turn TEM/TPS OFF”, perform the following steps.
- 2) At LPT Test Station, read the number of errors on the display. **Record** on the data sheet.
- 3) Review the recorded environmental profiles (CVS file). Verify the following:
 - a) Temperature of the TEM/TPS (thermo couplers TC 5 and TC 6) is +50 degrees C +2/-2C. **Record** minimum and maximum temperatures per the data sheet.
 - b) Pressure is less than 5×10^{-5} Torr. **Record** the maximum pressure per the data sheet.

Note: When two TEM/TPS assemblies are tested both test setups must meet the testing requirements before proceeding.

- 4) Turn the power OFF to the TEM/TPS as defined in Appendix C. **Record** per data sheet.
- 5) Click on “OK”.

5.3.11.2 Start of Shutdown Cycle of the Acceptance Test

- 1) Upon receipt of the prompt "OK to Start Temperature Transition" perform the following:
- 2) Notify the Test Director the Acceptance Thermal Vacuum Performance Testing is complete and ready to bring chamber to ambient temperature. **Record** per the data sheet.
- 3) Click on "OK" and wait for the prompt "Complete Acceptance Temp. Testing".
- 4) Monitor temperature of the TEM/TPS (thermo couples TC 5 and TC 6) is +30 degree ± 2 C. **Record** per the data sheet.

Note: When two TEM/TPS assemblies are tested both test setups must meet the testing requirements before proceeding.

- 5) Proceed to the section Shutdown of Chamber within this test procedure.

5.4 Chamber Shutdown

This section describes the procedure to shutdown the chamber by pressurization (venting), performing a comprehensive performance test, collecting test data, shutdown of the TEM/TPS and test equipment, and opening and closing the chamber.

5.4.1 Pressurization (Venting)

- 1) Vent the thermal vacuum chamber. Refer to GLAST Thermal Vacuum Chamber Operation Procedure LAT-TD-02541 to vent the thermal vacuum chamber.
- 2) Verify the chamber pressure is at ambient pressure 760 Torr. **Record** per the data sheet.
- 3) Verify the chamber temperature is +30 C +2/-2C. **Record** per the data sheet.
- 4) Perform the Comprehensive Performance Test at 20MHz. Refer to the TEM/TPS Performance Procedure LAT-TD-04085. **Record** per the data sheet.

Note: When two TEM/TPS assemblies are tested both test setups must meet the testing requirements before proceeding.

5.4.2 Opening Chamber

This section describes the procedure to lift the chamber so that the TEM/TPS unit can be removed from the chamber.

CAUTION: The chamber must be at ambient temperature before the lid is lifted. This is to prevent condensation on the TEM/TPS or hot/cold plate when the chamber is opened to the ambient environment.

- 1) Open the thermal vacuum chamber. Refer to GLAST Thermal Vacuum Chamber Operation Procedure LAT-TD-02541 to open the thermal vacuum chamber.

5.4.3 Collecting Test Data

- 1) Review and save the recorded environmental profiles (CVS files). **Record** per the data sheet.
- 2) Save and attach TEM/TPS Thermal Vacuum Test Data Sheets to Appendix A Cover. **Record** per the data sheet.
- 3) Save and print the recorded data, attach them to the Appendix A Cover. **Record** per the data sheet.

Appendix A (Data Sheets and Covers)

TEM/TPS Thermal Vacuum Test Procedure

COVER SHEET

Program: GLAST

Procedure Number: LAT-TD-03631

Procedure Title: TEM/TPS Thermal Vacuum Procedures

Paragraph Number: 5.0

Paragraph Title: Procedure

Unit S/N: _____

TEST READINESS REVIEW COMPLETED AND APPROVED BY THE FOLLOWING:

Test Director: _____ Date: _____

Quality Assurance: _____ Date: _____

Test Conductor: _____ Date: _____

REVIEWED AND APPROVED BY THE FOLLOWING:

Test Director: _____ Date: _____

Quality Assurance: _____ Date: _____

Test Conductor: _____ Date: _____

TEM/TPS Thermal Vacuum Test Procedure

TEST DATA SHEET		Unit S/N:	Date/Temperature:	
Title: 5.1.3 Test Equipment		Operator:	QA:	
Para./ Step	Test Equipment Description, Manufacturer	Model/LAT Number	Serial/Rev. Number	*Cal./Val. Date
5.1.3.1 - 1	Record Model/LAT number, Serial/Revision number, Calibration due dates and Validation date for all equipment used in this procedure:			
	VME Crate, Dawn VME Products	11-1011777-2119 VME64x (series 767)		
	VME, TST-STP Trans card	LAT-DS-00999		
	VME SBC MVME2304 card, Motorola	PN MVME2304-0123		
	VME LCB Mezzanine card	LAT-TD-00860		
	Software for the local PC	Record current LATTE version Found at www-glast.slac.stanford.edu/IntegrationTest/ONLINE/updates/		NA
	Software for the local PC	Record current TEMPROD version		NA
	DC Power supply #1, BK Precision	BK 1697		
	DC Power supply #2, BK Precision	BK 1697		
	28 Volt supply cable	LAT-DS-03246		
	PS Control cable	LAT-DS-04831		
	TEM to GASU cable	LAT-DS-02106		
	LCB Transition board cable	LAT-DS-03247		
	TEM Test Board Assembly	LAT-DS-04465		
	CAT5 Ethernet cable	TRD855PL-50		
	RS-232 Cable	TDC003-7 (RECO98M connectors)		
	Digital Multimeter, Fluke/Meterman	87-III/38XR		
	Connector Savers (28 pin), L Com	DGBH28MF		

* This column is used to enter the date that equipment is validated, when validated equipment is recorded in this data sheet.

TEM/TPS Thermal Vacuum Test Procedure

TEST DATA SHEET		Unit S/N:	Date/Temperature:	
Title: 5.1.3 Test Equipment		Operator:	QA:	
Para./ Step	Test Equipment Description, Manufacturer	Model/LAT Number	Serial/Rev. Number	*Cal./Val. Date
5.1.3.1 - 1	Record Model/LAT number, Serial/Revision number, Calibration due dates and Validation date for all equipment used in this procedure:			
	Connector Savers (51 pin), Glenair	MWDM2L-51USP1		
	Connector Savers (69 pin), SLAC	LAT-DS-04724		
	Thermal Vacuum Chamber, SLAC	LAT-DS-01043		
	Delay Line, Lemo To Bnc 4N, from SLAC Stores	STORES ID #078697		
	Thermal Vacuum Chamber, SLAC	LAT-DS-01043		
	Acrylic base adhesive tape, Saint Gobain	K102		
	Thermo coupler wire (8), Omega	T Type		
	DAQ Module, Omega	OMB-DAQ-55		
	DAQ Module, Omega	OMB-DAQ-56		
	Adaptor 28 Volt supply cable	LAT-DS-05663		
	Adaptor PS Control cable	LAT-DS-05661		
	Adaptor TEM to GASU cable	LAT-DS-05662		
	Torque Wrench	92407		

* This column is used to enter the date that equipment is validated, when validated equipment is recorded in this data sheet.

TEM/TPS Thermal Vacuum Test Procedure

TEST DATA SHEET		Unit S/N:	Date/Temperature:
Title: 5.1.4 Participant List		Operator:	QA:
Para./ Step	Title	Print Name	Signature
5.1.4 - 1	Record names of all personnel that take part in the test/operation:		

TEM/TPS Thermal Vacuum Test Procedure

TEST DATA SHEET		Start Time:	Date:	
Title: TEM/TPS Thermal Vacuum Test		Operator:	QA:	
Step	Description	Limits	Unit	Data
Test Setup				
5.2 -1	QAE notified to witness test setup		Yes/No	
5.2 -3-2	Verify torque of the 3/8 inch screws.	45	45 in/lbs	
	Verify torque of the 1/2 inch screws.	110	110 in/lbs	
TEM/TPS Test Setup Validation				
5.2.6 -1	Perform the Comprehensive Performance Test within the TEM/TPS Performance Procedure LAT-TD-04085		Yes/No	
5.2.7-1	Verify torque of the screws from the TEM/TPS to the adaptor plate.	20	20 in/lbs	
5.2.7-4	Verify that the TCs are reading 30°C	30°C +/- 2°C	Celsius	
5.2.8 -1	Perform the Comprehensive Performance Test within the TEM/TPS Performance Procedure LAT-TD-04085		YES/NO	

TEM/TPS Thermal Vacuum Test Procedure

TEST DATA SHEET		Unit S/N:		Date:		
				Time:		
Title: TEM/TPS Thermal Vacuum Test		Operator:		QA:		
Step	Description	Limits	Unit	Value	Pass/ Fail	Operator/ Time
Qualification Test						
5.3.2 Qualification Start Test						
-1	QAE notified to witness the Qualification test	YES	YES/NO			
5.3.2.1 Start of Qualification Test (Transition to Survival Hot)						
1	Verify the TEM/TPS is turned OFF.	OFF	OFF/ON			
5.3.2.2 Hot Survival Soak						
2 - a	Verify the temperature of the soak	+60 (+2/-2)	Celsius			
2 - b	Verify the duration of the soak.	=>4	Hours			
2 - c	Verify the pressure of the chamber during the soak	<5.0e-5	Torr			
2 - d	Verify end of bakeout	YES	YES/NO			
5.3.3.1 Hot Qualification Turn ON Test						
3 - a	Verify the temperature of the soak	+55 (+2/-2)	Celsius			
4 - a	Turn the power ON to the TEM/TPS.	ON	ON/OFF			
4 - b	Turn the power OFF to the TEM/TPS.	OFF	ON/OFF			
4 - c	Turn the power ON to the TEM/TPS.	ON	ON/OFF			
4 - e	Verify Limited Performance Test had no errors	0	counts			
5.3.3.2 Hot Qualification Soak						
2	Verify Limited Performance Test had no errors	0	counts			
3 - a	Verify the temperature of the soak	+55 (+2/-2)	Celsius			
3 - b	Verify the duration of the soak.	=>4	Hours			
3 - c	Verify the pressure of the chamber during the soak	<5.0e-5	Torr			

Hard copies of this document are for REFERENCE ONLY and should not be considered the latest revision.

TEM/TPS Thermal Vacuum Test Procedure

TEST DATA SHEET		Unit S/N:		Date:		
				Time:		
Title: TEM/TPS Thermal Vacuum Test		Operator:		QA:		
Step	Description	Limits	Unit	Value	Pass/ Fail	Operator/ Time
Qualification Test						
5.3.3.3 CPT Test						
1	Perform one Comprehensive Performance Test	OK	OK/NG			
2	Turn the power OFF to the TEM/TPS.	OFF	ON/OFF			
5.3.3.5 Cold Survival Soak						
1 - a	Verify the temperature of the soak	-40 (+2/-2)	Celsius			
1 - b	Verify the duration of the soak.	4 - 8	Hours			
1 - c	Verify the pressure of the chamber during the soak	<5.0e-5	Torr			
5.3.3.6 Cold Survival Turn ON						
1 - a	Turn the power ON to the TEM/TPS.	ON	ON/OFF			
1 - c	Verify Limited Performance Test had no errors	0	counts			
5.3.3.8 Cold Qualification Soak						
2	Verify Limited Performance Test had no errors	0	counts			
3 - a	Verify the temperature of the soak	-40 (+2/-2)	Celsius			
3 - b	Verify the duration of the soak.	4-8	Hours			
3 - c	Verify the pressure of the chamber during the soak	<5.0e-5	Torr			
5.3.3.9 CPT Test						
-1	Perform one Comprehensive Performance Test	OK	OK/NG			

Hard copies of this document are for REFERENCE ONLY and should not be considered the latest revision.

TEM/TPS Thermal Vacuum Test Procedure

TEST DATA SHEET		Unit S/N:		Date: Time:		
Title: TEM/TPS Thermal Vacuum Test		Operator:		QA:		
Step	Description	Limits	Unit	Value	Pass/ Fail	Operator/ Time
Qualification Test Cycle 2-11 (Copy this sheet for cycle 3-11)				Enter Cycle Number = _____		
5.3.4.1 Hot Qualification Temperature Soak						
3	Verify Limited Performance Test had no errors	0	counts			
4 - a	Verify the temperature of the soak	+55 (+2/-2)	Celsius			
4 - b	Verify the duration of the soak.	=>4	Hours			
4 - c	Verify the pressure of the chamber during the soak	<5.0e-5	Torr			
5.3.4.2 Hot Qualification Temperature Turn ON						
1	Turn the power OFF to the TEM/TPS.	OFF	ON/OFF			
2	Turn the power ON to the TEM/TPS.	ON	ON/OFF			
5.3.4.3 LPT Test						
1	Perform one Limited Performance Test	OK	OK/NG			
5.3.4.5 Cold Qualification Soak						
2	Verify Limited Performance Test had no errors	0	counts			
3 - a	Verify the duration of the soak.	4-8	Hours			
3 - b	Verify the pressure of the chamber during the soak	<5.0e-5	Torr			
3 - c	Verify the temperature of the soak	-40 (+2/-2)	Celsius			
5.3.4.6 Cold Qualification Temperature Turn ON						
1	Turn the TEM/TPS power to OFF.	OFF	ON/OFF			
2	Turn the TEM/TPS power to ON.	ON	ON/OFF			
5.3.4.7 LPT Test						
-1	Perform one Limited Performance Test	OK	OK/NG			

Hard copies of this document are for REFERENCE ONLY and should not be considered the latest revision.

TEM/TPS Thermal Vacuum Test Procedure

TEST DATA SHEET		Unit S/N:		Date: Time:		
Title: TEM/TPS Thermal Vacuum Test		Operator:		QA:		
Step	Description	Limits	Unit	Value	Pass/ Fail	Operator/ Time
Qualification Test Cycle 12						
5.3.5.1 Hot Qualification Temperature Soak						
2	Verify Limited Performance Test had no errors	0	counts			
3 - a	Verify the temperature of the soak	+55 (+2/-2)	Celsius			
3 - b	Verify the duration of the soak.	=>4	Hours			
3 - c	Verify the pressure of the chamber during the soak	<5.0e-5	Torr			
5.3.5.2 Hot Qualification Temperature Turn ON						
1	Turn the power OFF to the TEM/TPS.	OFF	ON/OFF			
2	Turn the power ON to the TEM/TPS.	ON	ON/OFF			
5.3.5.3 CPT Test						
1	Perform one Comprehensive Performance Test	OK	OK/NG			
5.3.5.5 Cold Qualification Soak						
2	Verify Limited Performance Test had no errors	0	counts			
3 - a	Verify the temperature of the soak	-40 (+2/-2)	Celsius			
3 - b	Verify the duration of the soak.	4-8	Hours			
3 - c	Verify the pressure of the chamber during the soak	<5.0e-5	Torr			
5.3.5.6 Cold Qualification Temperature Turn ON						
1	Turn the power OFF to the TEM/TPS.	OFF	ON/OFF			
2	Turn the power ON to the TEM/TPS.	ON	ON/OFF			
5.3.5.7 CPT Test						
1	Perform one Comprehensive Performance Test	OK	OK/NG			

Hard copies of this document are for REFERENCE ONLY and should not be considered the latest revision.

TEM/TPS Thermal Vacuum Test Procedure

TEST DATA SHEET		Unit S/N:		Date: Time:		
Title: TEM/TPS Thermal Vacuum Test		Operator:		QA:		
Step	Description	Limits	Unit	Value	Pass/ Fail	Operator/ Time
Qualification Shutdown Cycle						
5.3.6.1 Hot Qualification Temperature Short Soak (End of cycle 12)						
2	Verify Limited Performance Test had no errors	0	counts			
3 – a	Verify the temperature of the soak	+55 (+2/-2)	Celsius			
3 – b	Record the pressure of the chamber	<5.0e-5	Torr			
4	Turn the TEM/TPS power to OFF.	OFF	ON/OFF			
5.3.6.2 Start of Shut down						
2	Test Director notified the Qualification Test is complete	YES	YES/NO			
4	Verify the TEM/TPS temperature	+30 (+2/-2)	Celsius			

Hard copies of this document are for REFERENCE ONLY and should not be considered the latest revision.

TEM/TPS Thermal Vacuum Test Procedure

TEST DATA SHEET		Unit S/N:		Date:		
				Time:		
Title: TEM/TPS Thermal Vacuum Test		Operator:		QA:		
Step	Description	Limits	Unit	Value	Pass/ Fail	Operator/ Time
Acceptance Test						
5.3.7 Acceptance Start Test						
-1	QAE notified to witness the Acceptance test	YES	YES/NO			
5.3.7.1 Start of Acceptance Test (Transition to Survival Hot)						
1	Verify the TEM/TPS is turned OFF.	OFF	OFF/ON			
5.3.7.2 Hot Survival Soak						
2 - a	Verify the temperature of the soak	+60 (+2/-2)	Celsius			
2 - b	Verify the duration of the soak.	=>4	Hours			
2 - c	Verify the pressure of the chamber during the soak	<5.0e-5	Torr			
2 - d	Verify end of bakeout	YES	YES/NO			
5.3.8.1 Hot Acceptance Turn ON Test						
2 - a	Verify the temperature of the soak	+50 (+2/-2)	Celsius			
3 - a	Turn the power ON to the TEM/TPS.	ON	ON/OFF			
3 - b	Turn the power OFF to the TEM/TPS.	OFF	ON/OFF			
3 - c	Turn the power ON to the TEM/TPS.	ON	ON/OFF			
3 - e	Verify Limited Performance Test had no errors	0	counts			
5.3.8.2 Hot Acceptance Soak						
2	Verify Limited Performance Test had no errors	0	counts			
3 - a	Verify the temperature of the soak	+50 (+2/-2)	Celsius			
3 - b	Verify the duration of the soak.	=>4	Hours			
3 - c	Verify the pressure of the chamber during the soak	<5.0e-5	Torr			
5.3.8.3 CPT Test						
1	Perform one Comprehensive Performance Test	OK	OK/NG			
2	Turn the power OFF to the TEM/TPS.	OFF	ON/OFF			

Hard copies of this document are for REFERENCE ONLY and should not be considered the latest revision.

TEM/TPS Thermal Vacuum Test Procedure

TEST DATA SHEET		Unit S/N:		Date:		
				Time:		
Title: TEM/TPS Thermal Vacuum Test		Operator:		QA:		
Step	Description	Limits	Unit	Value	Pass/ Fail	Operator/ Time
Acceptance Test						
5.3.8.5 Cold Survival Soak						
1 - a	Verify the temperature of the soak	-40 (+2/-2)	Celsius			
1 - b	Verify the duration of the soak.	4 - 8	Hours			
1 - c	Verify the pressure of the chamber during the soak	<5.0e-5	Torr			
5.3.8.6 Cold Survival Turn ON						
1 - a	Turn the power ON to the TEM/TPS.	ON	ON/OFF			
1 - c	Verify Limited Performance Test had no errors	0	counts			
5.3.8.8 Cold Acceptance Soak						
2	Verify Limited Performance Test had no errors	0	counts			
3 - a	Verify the temperature of the soak	-35 (+2/-2)	Celsius			
3 - b	Verify the duration of the soak.	4-8	Hours			
3 - c	Verify the pressure of the chamber during the soak	<5.0e-5	Torr			
5.3.8.9 CPT Test						
-1	Perform one Comprehensive Performance Test	OK	OK/NG			

Hard copies of this document are for REFERENCE ONLY and should not be considered the latest revision.

TEM/TPS Thermal Vacuum Test Procedure

TEST DATA SHEET		Unit S/N:		Date:		
				Time:		
Title: TEM/TPS Thermal Vacuum Test		Operator:		QA:		
Step	Description	Limits	Unit	Value	Pass/ Fail	Operator/ Time
Acceptance Test Cycle 2-3 (Copy this sheet for cycle 3)				Enter Cycle Number = _____		
5.3.9.1 Hot Acceptance Temperature Soak						
3	Verify Limited Performance Test had no errors	0	counts			
4 - a	Verify the temperature of the soak	+50 (+2/-2)	Celsius			
4 - b	Verify the duration of the soak.	=>4	Hours			
4 - c	Verify the pressure of the chamber during the soak	<5.0e-5	Torr			
5.3.9.2 Hot Acceptance Temperature Turn ON						
1	Turn the power OFF to the TEM/TPS.	OFF	ON/OFF			
2	Turn the power ON to the TEM/TPS.	ON	ON/OFF			
5.3.9.3 LPT Test						
1	Perform one Limited Performance Test	OK	OK/NG			
5.3.9.5 Cold Acceptance Soak						
2	Verify Limited Performance Test had no errors	0	counts			
3 - a	Verify the duration of the soak.	4-8	Hours			
3 - b	Verify the pressure of the chamber during the soak	<5.0e-5	Torr			
3 - c	Verify the temperature of the soak	-35 (+2/-2)	Celsius			
5.3.9.6 Cold Acceptance Temperature Turn ON						
1	Turn the TEM/TPS power to OFF.	OFF	ON/OFF			
2	Turn the TEM/TPS power to ON.	ON	ON/OFF			
5.3.9.7 LPT Test						
-1	Perform one Limited Performance Test	OK	OK/NG			

Hard copies of this document are for REFERENCE ONLY and should not be considered the latest revision.

TEM/TPS Thermal Vacuum Test Procedure

TEST DATA SHEET		Unit S/N:		Date:		
Title: TEM/TPS Thermal Vacuum Test		Operator:		Time:		
Title: TEM/TPS Thermal Vacuum Test		Operator:		QA:		
Step	Description	Limits	Unit	Value	Pass/ Fail	Operator/ Time
Acceptance Test Cycle 4						
5.3.10.1 Hot Acceptance Temperature Soak						
2	Verify Limited Performance Test had no errors	0	counts			
3 - a	Verify the temperature of the soak	+50 (+2/-2)	Celsius			
3 - b	Verify the duration of the soak.	=>4	Hours			
3 - c	Verify the pressure of the chamber during the soak	<5.0e-5	Torr			
5.3.10.2 Hot Acceptance Temperature Turn ON						
1	Turn the power OFF to the TEM/TPS.	OFF	ON/OFF			
2	Turn the power ON to the TEM/TPS.	ON	ON/OFF			
5.3.10.3 CPT Test						
1	Perform one Comprehensive Performance Test	OK	OK/NG			
5.3.10.5 Cold Acceptance Soak						
2	Verify Limited Performance Test had no errors	0	counts			
3 - a	Verify the temperature of the soak	-35 (+2/-2)	Celsius			
3 - b	Verify the duration of the soak.	4-8	Hours			
3 - c	Verify the pressure of the chamber during the soak	<5.0e-5	Torr			
5.3.10.6 Cold Acceptance Temperature Turn ON						
1	Turn the power OFF to the TEM/TPS.	OFF	ON/OFF			
2	Turn the power ON to the TEM/TPS.	ON	ON/OFF			
5.3.10.7 CPT Test						
1	Perform one Comprehensive Performance Test	OK	OK/NG			

Hard copies of this document are for REFERENCE ONLY and should not be considered the latest revision.

TEM/TPS Thermal Vacuum Test Procedure

TEST DATA SHEET		Unit S/N:		Date: Time:		
Title: TEM/TPS Thermal Vacuum Test		Operator:		QA:		
Step	Description	Limits	Unit	Value	Pass/ Fail	Operator/ Time
Acceptance Shutdown Cycle						
5.3.11.1 Hot Acceptance Temperature Short Soak (End of cycle 4)						
2	Verify Limited Performance Test had no errors	0	counts			
3 - a	Verify the temperature of the soak	+50(+2/-2)	Celsius			
3 - b	Record the pressure of the chamber	<5.0e-5	Torr			
4	Turn the TEM/TPS power to OFF.	OFF	ON/OFF			
5.3.11.2 Start of Shut down						
2	Test Director notified the Acceptance Test is complete	YES	YES/NO			
4	Verify the TEM/TPS temperature	+30 (+2/-2)	Celsius			

Hard copies of this document are for REFERENCE ONLY and should not be considered the latest revision.

TEM/TPS Thermal Vacuum Test Procedure

TEST DATA SHEET		Unit S/N:	Date:	
Title: TEM/TPS Thermal Vacuum Test		Operator:	QA:	
Step	Description	Limits	Unit	Operator
Chamber Shutdown				
5.4 Chamber Shutdown				
5.4.1 - 2	Verify the pressure of the chamber.	760	Torr	
5.4.1 - 3	Verify the temperature of the TEM/TPS.	+30 (+2/-2)	Celsius	
5.4.1 - 4	Perform the Comprehensive Performance Test within the TEM/TPS Performance Procedure LAT-TD-04085.	OK	OK/NG	
5.4.3 Collecting Test Data				
-1	Review and save the recorded environmental profiles (CVS files).	YES	YES/NO	
-2	Save and attach TEM/TPS Thermal Vacuum Test Data Sheets	YES	YES/NO	
-3	Save, print, and attach Recorded Profiles	YES	YES/NO	

Hard copies of this document are for REFERENCE ONLY and should not be considered the latest revision.

Appendix B (Connector Mate/Demate Log)

Appendix C (CPT and LPT definition)

Comprehensive Performance Tests (CPT)

- 1) Refer to the TEM/TPS Performance Test Procedure LAT-TD-04085 and perform the following:
 - a) To perform CPT during TV, run only sections 5.5 and 5.6. Attach data sheets to Appendix A.

Limited Performance Tests (LPT)

- 1) Refer to the TEM/TPS Performance Test Procedure LAT-TD-04085 and perform the following:
 - a) To perform LPT during TV, run LPT paragraph 5.5.1 to turn on FE voltages and 5.5.5 to run test.
 - b) For continuous LPT set “test configuration” to infinite mode by setting number of iterations to -1.

TEM/TPS Power Turn ON and OFF

- 1) To turn the power ON to the TEM/TPS perform the following:
 - a) Turn on power supply 1 at 28.0 volts.
 - b) Turn on power supply 2 at 3.6 volts.
 - c) Turn on VME crate.
- 2) To turn the power OFF to the TEM/TPS perform the following:
 - a) Turn off power supply 1 at 28.0 volts.
 - b) Turn off power supply 2 at 3.6 volts.
 - c) Turn off VME crate.

Appendix D (Emergency Shut-Down Procedure)

Emergency Shut-Down Procedure

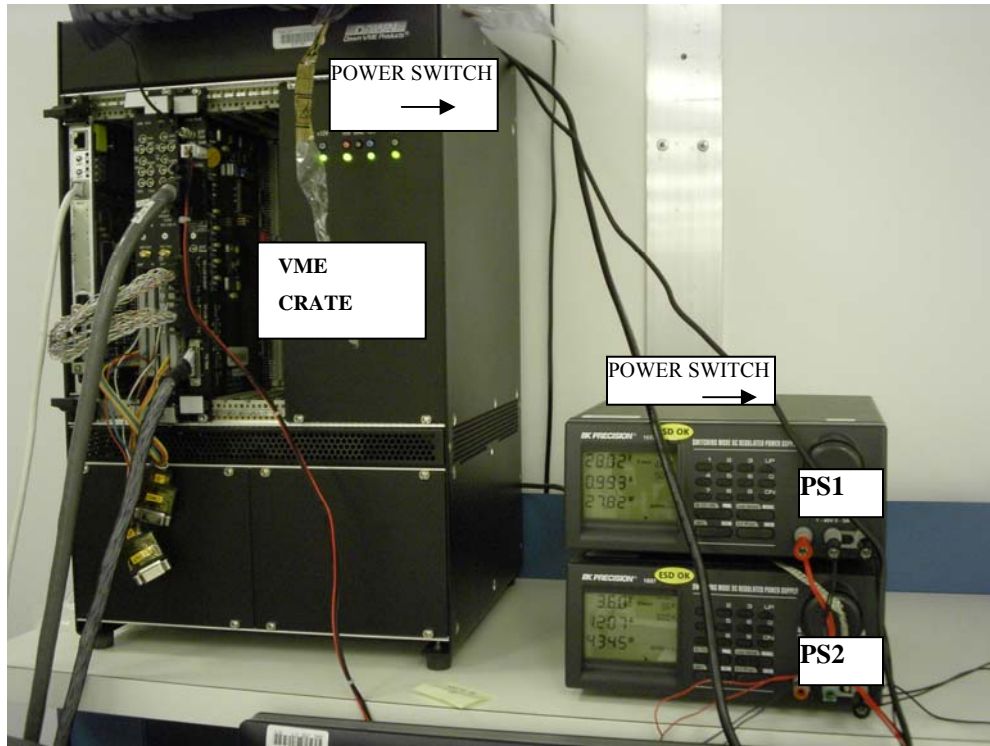

In case of emergency both power supplies (PS1 and PS2) and VME crate need to be shut down. This is accomplished by switching OFF power switches located on back side of each unit.

Conditions which contribute to emergency:

- Measured temperature of TV chamber above 63C or bellow -43C
- Pressure in TV chamber dropped bellow $2e-3$
- TV cooling/heating unit in an emergency shut down

Call immediately to the following support personal:

- The Responsible Engineer(s) for the equipment under test
- The I& T Mechanical and Electrical Engineers
- Quality (Product Assurance)

Hard copies of this document are for REFERENCE ONLY and should not be considered the latest revision.