

GLAST Large Area Telescope:

Integration and Test -Electrical Test- Phase 0 TRR

- Key Requirements Documents
- Electrical Test procedures and status
- EGSE Hardware configuration
- Flight PDU/ EM GASU/ ACD Integration flow

Brian Grist
Integration and Test
SLAC

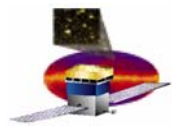

Key I&T Requirement Documents

Document	Released Revision
LAT-MD-00408-04c LAT Instrument Performance Verification Plan	4/7/05
LAT-MD-02730-02d2 LAT Performance and Operations Test Plan	6/7/05
LAT-MD-00676-04 LAT Assembly Sequence	9/1/05
LAT-MD-00895-04 LAT Instrument Survey Plan	2/1/05
LAT-DS-05210-52 LAT Systems KIT, Cable Installation	11/2/05
LAT-DS-02563-02 LAT Instrument Assembly	10/28/05
LAT-DS-06721-02 External Cable Assembly	Sign-off

Requirements Definition Key to Successful I&T

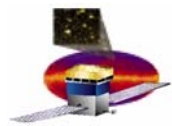

IFCT Electrical Procedures and Status

**25 of 26 electrical
test procedures
complete**

**1 in draft waiting
further test
definitions**

Document #	Status	Document Title
LAT-MD-01533	Released	EGSE Plan
LAT-PS-03276	Released	LAT EGSE Setup and Validation Procedure
LAT-PS-03287	Released	Cal Module Test Procedure
LAT-PS-03290	Released	Tracker Module Test Procedure
LAT-TD-03875	Released	TEM EICIT Procedure
LAT-TD-04097	Released	TEM SVT Procedure
LAT-TD-04098	Released	TPS SVT Procedure
LAT-TD-04099	Released	TPS EICIT Procedure
LAT-TD-04260	Released	GASU EICIT Procedure (Manual)
LAT-TD-04325	Released	ATP, Break out Boxes and Cables
LAT-TD-04332	Released	PDU EICIT Procedure
LAT-TD-04382	Released	Flight GASU SVT Procedure
LAT-TD-04384	Released	Flight PDU SVT Procedure
LAT-PS-04459	Released	Mate and Demate Workmanship Standard
LAT-PS-04511	Released	Data Collection Procedure
LAT-PS-04512	Released	Single Tower Test Procedure
LAT-PS-05504	Released	Computing Infrastructure
LAT-PS-05527	Released	I&T Test Stand Setup Procedure
LAT-PS-05736	Released	LATTE and Components Installation
LAT-PS-06610	Released	GASU EICIT Procedure (Auto)
LAT-PS-06817	Released	Electrical Bonding Measurement Procedure
LAT-PS-07074	Released	Parallel LAT Testing
LAT-PS-07125	Released	ACD STM
LAT-PS-07172	Released	ACD CPT
LAT-PS-07469	Draft	LAT Trigger Tests
LAT-PS-07575	01 Released, 02 in signoff	LAT Integration STM

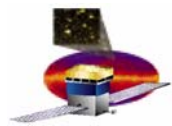

EGSE Hardware configuration

Phase 0 EGSE configuration the same as the past tower integration, with the addition of a Flight PDU, HIBs, and cables

Flight Hardware

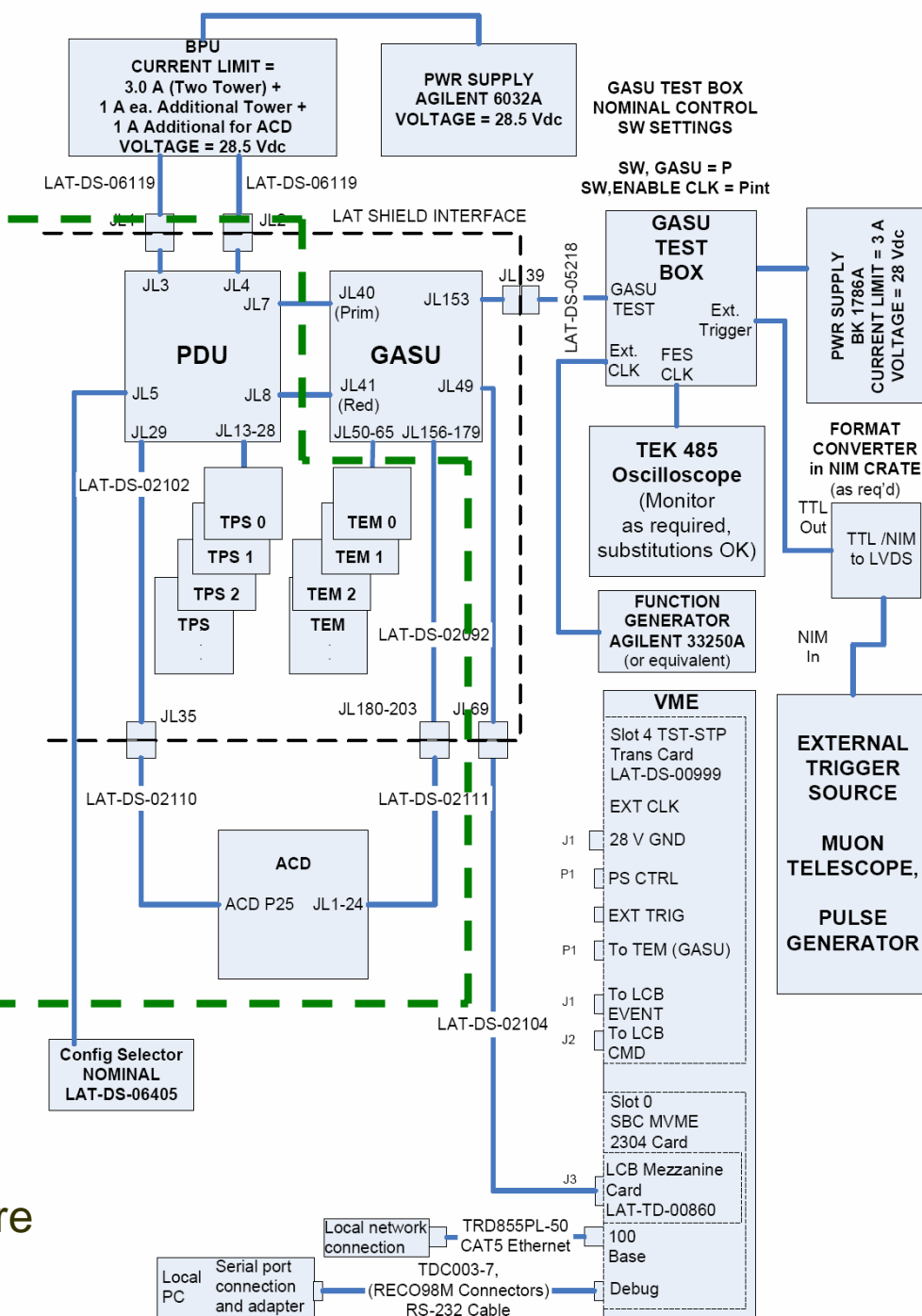

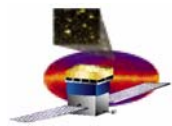

Flight PDU/EMGASU/ACD Integration Sequence

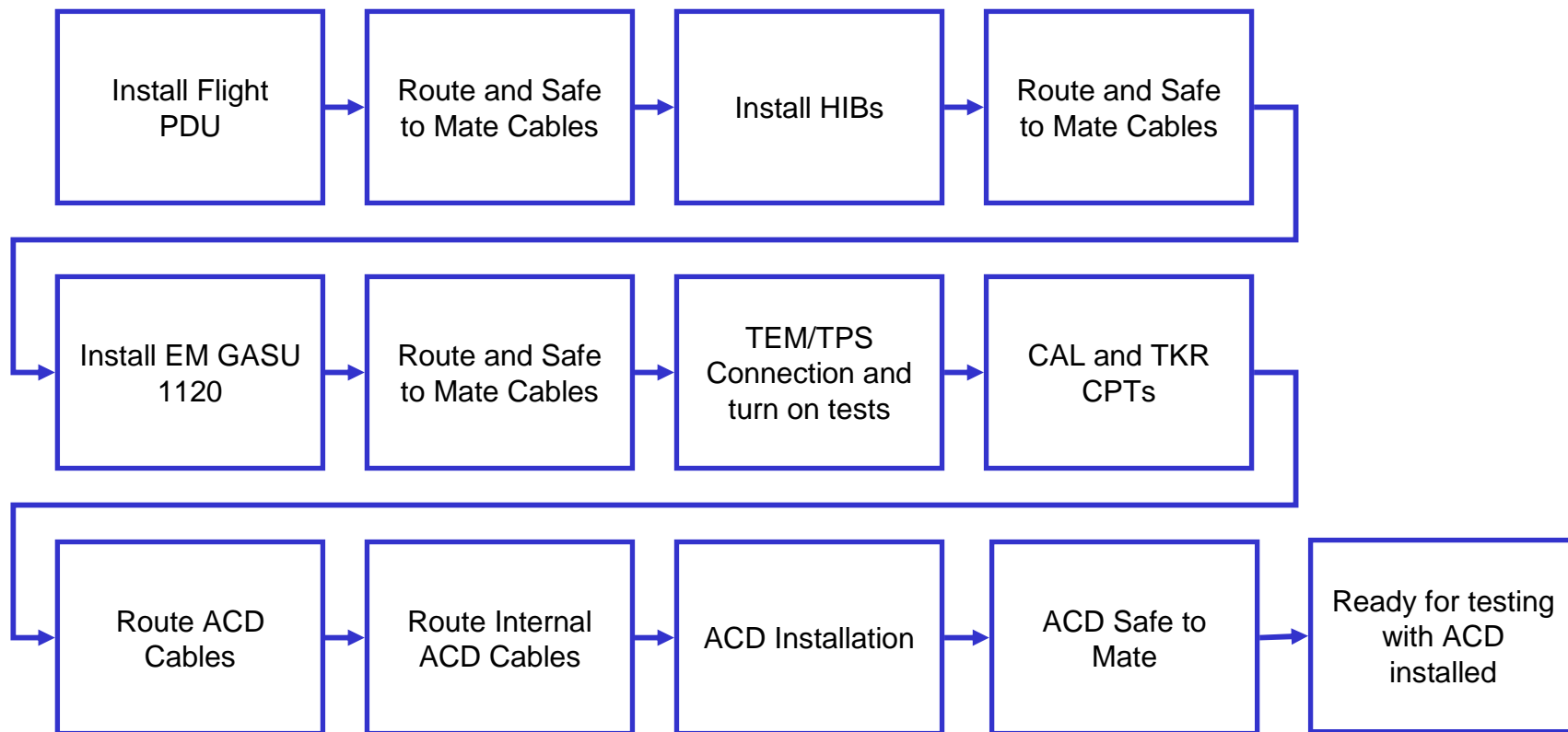

A 93 step Assembly Instruction Data Sheet (#1767) is complete and approved to perform this sequence