

REV	DESCRIPTION	DATE	BY	CHKD	APPV
1	CHANGED J2-J10 FROM HANMONICS TO OMNINETICS CONNECTORS	05/05/03	DJN	RFJ	DJN
2	ADDED R7-R22, USED TO TERMINATE NSDATA AND NTOKEN	12/10/03	DJN	RFJ	DJN
3	ADDED R23-R24, USED TO BIAS NSDATA_ORI_INP	12/15/03	DJN	RFJ	DJN
4	ADDED R25-R32, USED TO LIMIT CURRENT IF AN HCM SHORTS	1/29/04	DJN	RFJ	DJN
5	REMOVED R7-R22 BECAUSE NEW STFC ASICS WERE FIXED	02/03/04	DJN	RFJ	DJN

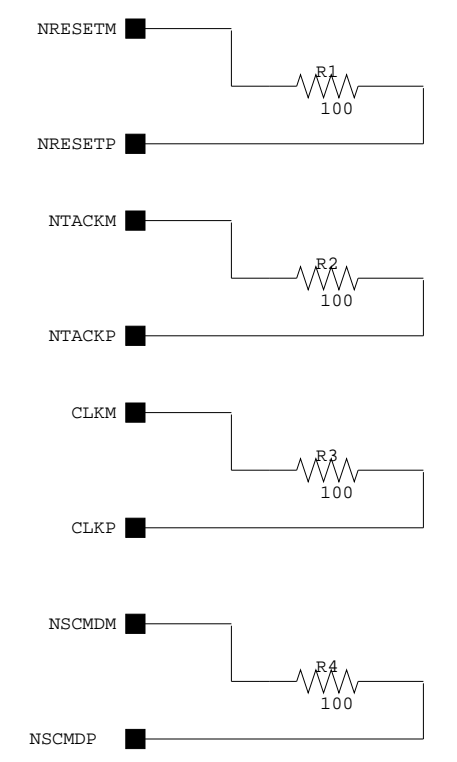
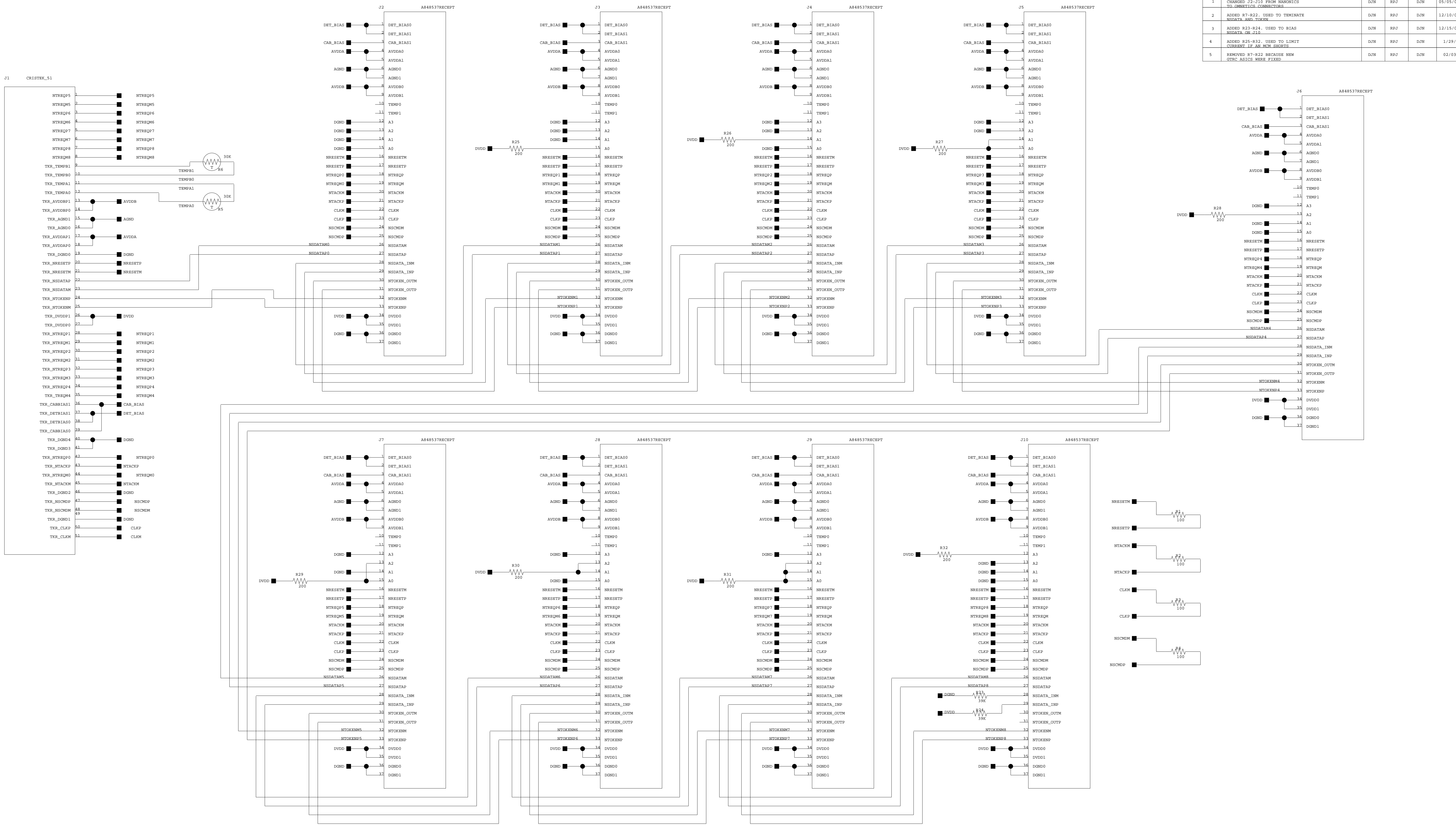

STANFORD LINEAR ACCELERATOR CENTER U.S. DEPARTMENT OF ENERGY			
STANFORD UNIVERSITY		STANFORD, CALIFORNIA	
PROPRIETARY DATA OF STANFORD UNIVERSITY AND/OR U.S. DEPARTMENT OF ENERGY. RECIPIENT SHALL NOT PUBLISH THE INFORMATION WITHIN UNLESS GRANTED SPECIFIC PERMISSION OF STANFORD UNIVERSITY.			
INSR	DAVID NELSON	DATE	8/15/01
OPFR	DAVID NELSON	DATE	8/15/01
CHSR		DATE	