

GLAST Large Area Telescope:

AntiCoincidence Detector (ACD) Overview WBS 4.1.6

David J. Thompson
NASA Goddard Space Flight Center
ACD Subsystem Manager

djt@egret.gsfc.nasa.gov

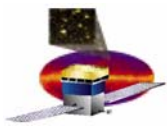

Outline - ACD

- **Overview**
- **Level III Requirements Summary**
- **Heritage**
- **Responses to Recommendations**
- **Status**
- **WBS Interfaces**
- **Organization**
- **Schedule Milestones**
- **Cost Plan**

Anticoincidence Detector Overview

Prototype ACD tile
read out with
Wavelength Shifting
Fiber

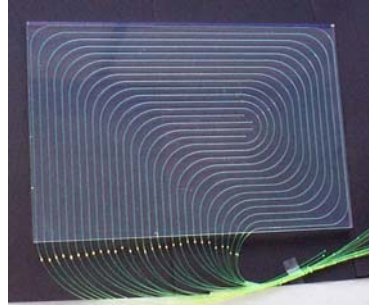

Tile Shell Assembly
(TSA)

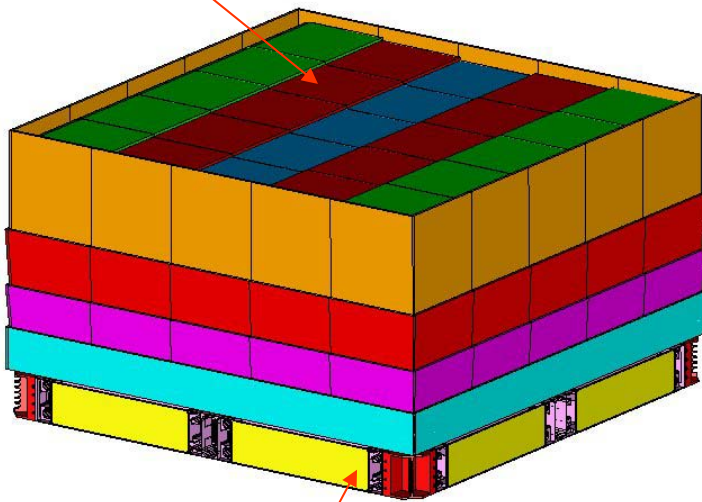

Base Electronics
Assembly (BEA)

• TILE SHELL ASSEMBLY

- 89 Plastic scintillator tiles
- Waveshifting fiber light collection (with clear fiber light guides for long runs)
- Two sets of fibers for each tile
- Tiles overlap in one dimension
- 8 scintillating fiber ribbons cover gaps in other dimension (not shown)
- Supported on self-standing composite shell
- Covered by thermal blanket + micrometeoroid shield (not shown)

• BASE ELECTRONICS ASSEMBLY

- 194 photomultiplier tube sensors (2/tile)
- 12 electronics boards (two sets of 6), each handling up to 18 phototubes. High voltage power supply on each board.



Level III Key Requirements Summary

Reference: LAT-SS-00016

Parameter	Requirement	Expected Performance	Verification Method
Detection of Charged Particles	≥ 0.9997 average detection efficiency over entire area of ACD (less for bottom row of tiles)	≥ 0.9997 ≥ 0.99 (bottom tiles)	Test and Analysis
Fast VETO signal	Logic signal 50-700 nsec after passage of charged particle	50-700 nsec	Test
PHA signal	For each phototube, pulse height measurement for each Trigger Acknowledge (TACK) Below 10 MIP, precision of < 0.02 MIP or 5% (whichever larger) Above 10 MIP, precision of < 1 MIP or 2% (whichever larger)	< 0.02 MIP or 5% < 1 MIP or 2%	Test and Analysis
False VETO rate - backsplash	$< 20\%$ false VETO's due to calorimeter backsplash at 300 GeV	$< 20\%$	Analysis
False VETO rate - noise	$< 1\%$ gamma-ray rejection from false VETO's due to electrical noise	$< 1\%$	Analysis
High Threshold (Heavy Nuclei) Detection	Detection of highly-ionized particles (C-N-O or heavier) for calorimeter calibration.	Yes	Test and Analysis
Size	Outside: 1796 x 1796 x 1015 mm Inside Grid: 1574 x 1574 x 204.7 mm Inside TKR: 1515.5 x 1515.5 x 650 mm	1796 x 1796 x 1015 1574 x 1574 x 204.7 1515.5 x 1515.5 x 650	Test
Mass	< 205 kg	228	Test
Power	< 31 Watts (conditioned)	24	Test
Instrument Lifetime	Minimum 5 yrs	> 5 yr.	Analysis

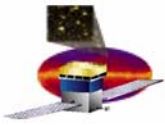

ACD Heritage

- **Plastic Scintillator** - used in all previous gamma-ray telescopes OSO-3, SAS-2, COS-B, CGRO (all 4 instruments), plus many cosmic ray experiments.
- **Waveshifting fibers** - used in GLAST LAT Balloon Flight Engineering Model (BFEM). Waveshifting bars used by HEXTE on RXTE (same material in a different geometry)
- **Photomultiplier tubes** - used in all previous gamma-ray telescopes. HEXTE/RXTE used a commercial version of the same tube we are using (Hamamatsu 4443), and GOLF on SOHO used the same tube as the ACD except for the cathode material (Hamamatsu 4444)
- **High Voltage Bias Supplies** - used in all previous gamma-ray telescopes. The designer of the ACD HVBS designed one of the EGRET supplies.
- **Electronics** - similar ASIC's (same designer) used on the BFEM. Electronics group has substantial space flight experience.
- **Micrometeoroid Shield** - Improved version (more layers, stronger materials) of shield that protected EGRET successfully for nine years.

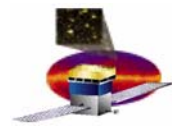

ACD Responses to Recommendations

From the February review:

1. Perform optimization of the optics design: **LAT-TD-00438-D2, LAT ACD Light Collection/Optical Performance Tests** reports results of design tests, including adding clear fibers and optimized number of fibers.
2. Perform tests (bench measurements/Monte Carlo/Balloon) to prove that scintillating fiber ribbons reduce inefficiency of the ACD in the crack region (2-3 millimeters) to the level that satisfies the physics requirements of the GLAST mission. **Same document reports preliminary laboratory tests; additional tests are ongoing.**
3. Provide complete technical drawings for mounting of tiles and readout photomultiplier tubes on the support structure. **The design is essentially complete; phototubes have been moved to base area.**
4. Perform a full bottoms-up cost estimate, including realistic fabrication, assembly, and installation scenario, with contingency covering possible increases of cost. **Cost estimate was done; descope was necessary.**

From the August review:

For the baseline review it would be useful to review the performance requirements placed on the ACD by the science goals of the project and to understand the proposed allocation of resources. **Performance requirements have been re-examined, and we are prepared to discuss resources needed to meet them.**

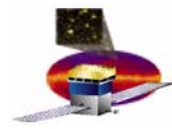

Anticoincidence Detector Status

- **Designs for the Tile Shell Assembly (TSA) and Base Electronics Assembly (BEA) have been finished.**
- **Contract was established with Fermilab for preparing the scintillator tiles. Prototype Tile Detector Assemblies are being made now.**
- **A preliminary version of the analog ASIC has been made and is being prepared for testing. A second prototype is in fab.**
- **A contract has been signed with Hamamatsu for purchase of the photomultiplier tubes.**
- **All action items that were identified at the pre-PDR review have been completed.**
- **Cost and schedule show minor variances from plan, not in critical path.**
- **Descope and rebudgeting of the ACD was completed. Integration of revised WBS, schedule, and interfaces into PMCS is nearly done.**
- **Analysis of reliability and possible failure modes was carried out:**
 - **Two sets of fibers, 2 phototubes per tile, with separate electronics.**
 - **12 electronics cards (2 sets of 6), each with a high voltage supply.**

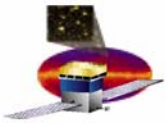

ACD Subsystem WBS Interfaces

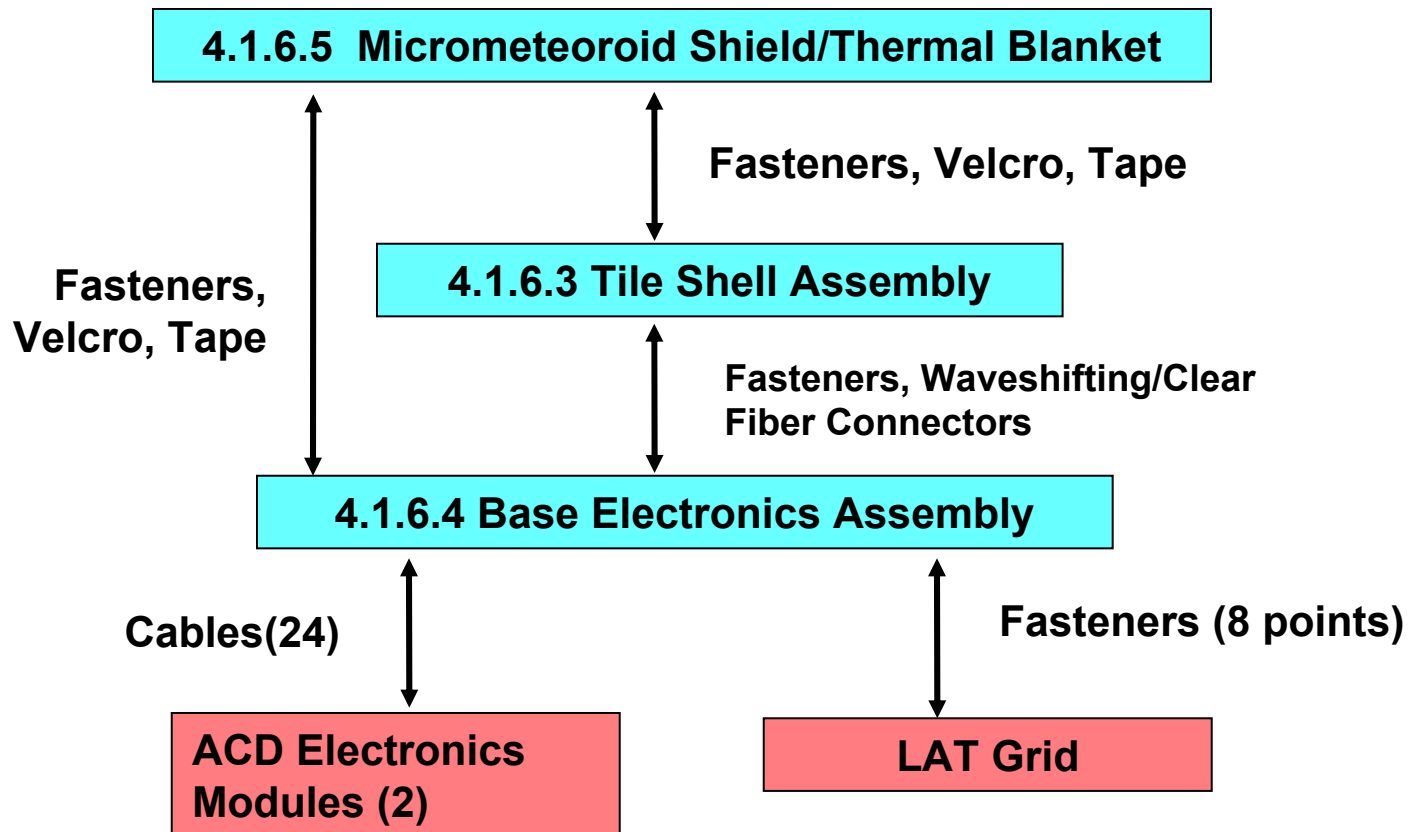

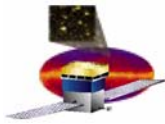

ACD Organization Chart

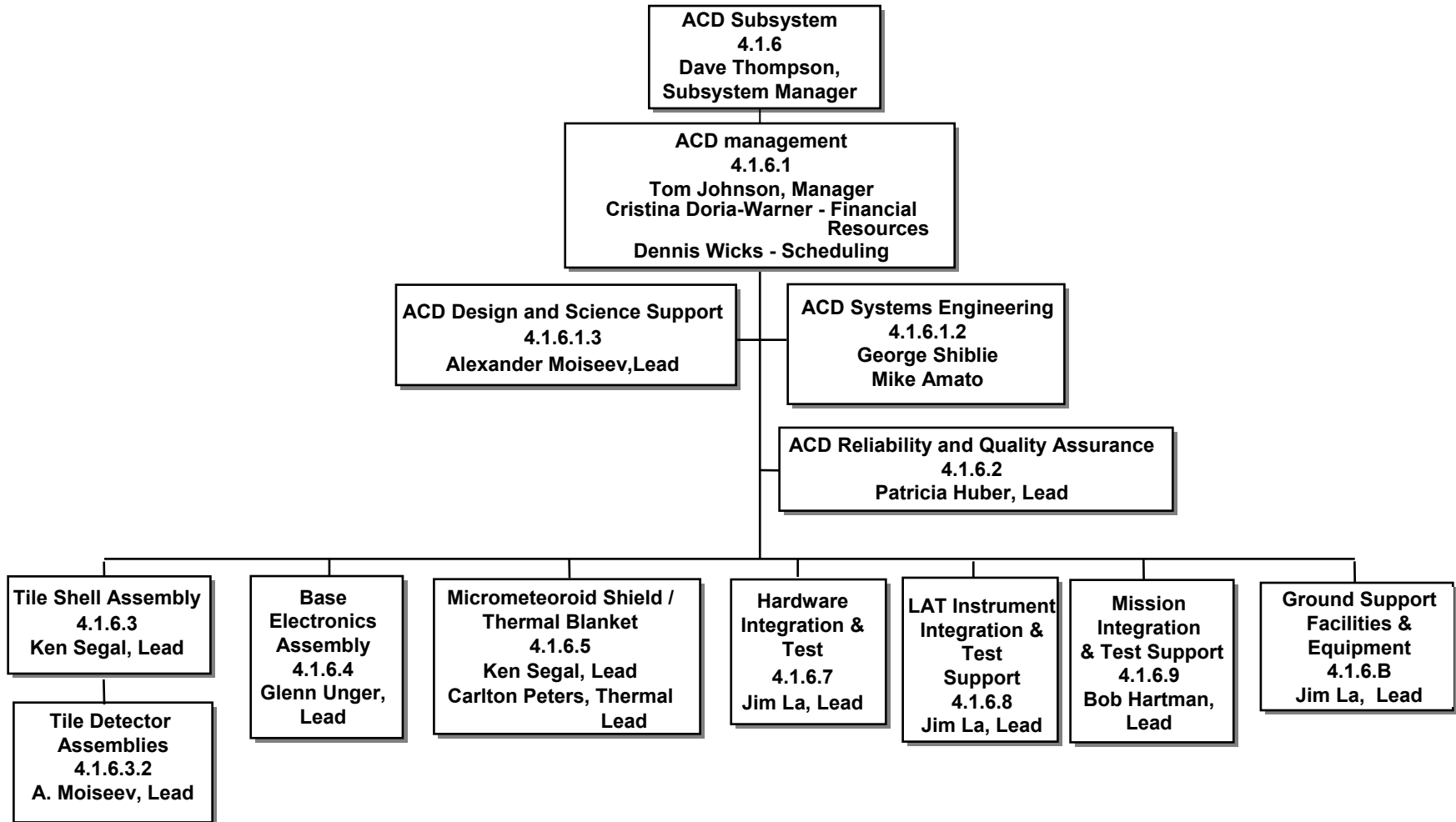

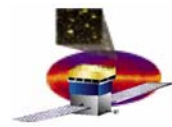

Level 3 Key Milestones

ACD Subsystem Requirements Review	03/20/01
Anticoincidence Detector PDR	07/25/01
Prototype Electronics Module (Elec to ACD)	03/15/02
EGSE Workstation / Software #1 (I&T to ACD)	03/15/02
High Voltage Power Supply (Bd & Prts)-ACD to Elec	06/03/02
Anticoincidence Detector CDR	06/26/02
Test/Screening Board w/ASIC for EM1 -ACD to Elec	07/01/02
Doc defining Calibration Model (ACD to I&T)	01/03/03
(11) FREE Bds & ASICS, (1) Fully Tested Bd - EM2	03/03/03
Flight Grid Ready for ACD Fit Test-(Mech to ACD)	05/08/03
ACD Calibration Test Unit at SLAC, Tested & RFI	11/03/03
ACD Test Scripts (from ACD to I&T)	02/02/04
ACD Flight Unit at SLAC, Tested/Inspected & RFI	04/26/04

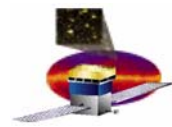

Selected Level IV Milestones

HVBS Decision	04/30/01
PMT Specification	07/13/01
Ten qual unit photomultiplier tubes received	03/01/02
First flight-like Analog ASIC received	03/07/02
First Digital ASIC received	04/02/02
Micrometeoroid Shield Design complete	06/13/02
Engineering Tile Detector Assemblies tested	07/02/02
Flight Base Frame delivered to GSFC	08/16/02
Flight Tile Detector Assemblies received	09/19/02
Flight HVPS Units tested	01/14/03
Flight Shell delivered to GSFC	02/25/03
Flight TDA Acceptance Testing complete	03/17/03
Flight Base Frame complete	03/19/03
ACD Mech Subsys Vibe Test complete	05/07/03
PMT & Divider Network Test complete	06/03/03
Flight TSA I&T complete	08/25/03
Flight BEA I&T complete	10/01/03
Flight ACD Environmental tests complete	03/30/04

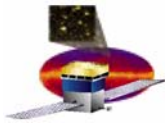

ACD Cost & Commitments

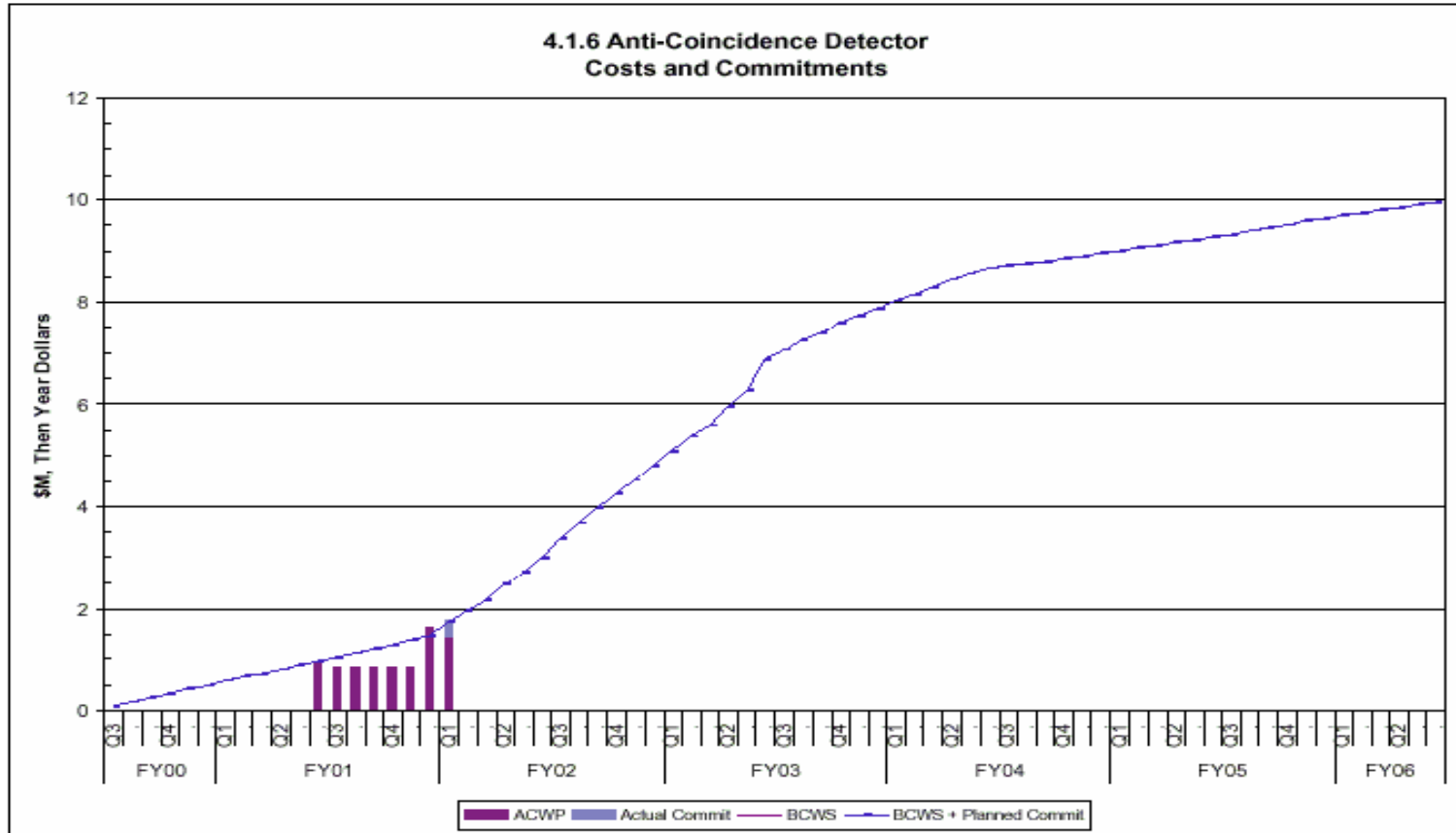



ACD Cost

